

Long distance transmission in few-mode fibers

Fatih Yaman,^{1,3,*} Neng Bai,¹ Benyuan Zhu,² Ting Wang,³ and Guifang Li^{1,4}

¹College of Optics and Photonics/CREOL&FPCE, University of Central Florida, 4000 Central Florida Blvd., Orlando 32816-2700, Florida, USA

²OFS Labs, 19 Schoolhouse Rd., Somerset 08873, New Jersey, USA

³NEC Laboratories America, Inc., 4 Independence Way, Suite 200, Princeton 08540, New Jersey, USA

⁴li@creol.ucf.edu

*fyaman@creol.ucf.edu

Abstract: Using multimode fibers for long-haul transmission is proposed and demonstrated experimentally. In particular few-mode fibers (FMFs) are demonstrated as a good compromise since they are sufficiently resistant to mode coupling compared to standard multimode fibers but they still can have large core diameters compared to single-mode fibers. As a result these fibers can have significantly less nonlinearity and at the same time they can have the same performance as single-mode fibers in terms of dispersion and loss. In the absence of mode coupling it is possible to use these fibers in the single-mode operation where all the data is carried in only one of the spatial modes throughout the fiber. It is shown experimentally that the single-mode operation is achieved simply by splicing single-mode fibers to both ends of a 35-km-long dual-mode fiber at 1310 nm. After 35 km of transmission, no modal dispersion or excess loss was observed. Finally the same fiber is placed in a recirculating loop and 3 WDM channels each carrying 6 Gb/s BPSK data were transmitted through 1050 km of the few-mode fiber without modal dispersion.

©2010 Optical Society of America

OCIS codes: (060.2330) Fiber optics communications; (060.1660) Coherent communications; (060.4370) Nonlinear optics, fibers; (190.4370) Nonlinear optics, fibers.

References and links

1. N. S. Bergano, "Wavelength division multiplexing in long-haul transoceanic transmission systems," *J. Lightwave Technol.* **23**(12), 4125–4139 (2005).
2. P. Nouchi, P. Sansonetti, S. Landais, G. Barre, C. Brehm, J. Y. Boiort, B. Perrin, J. J. Girard, and J. Auge, "Low-loss single-mode fiber with high nonlinear effective area," in *Optical Fiber Communications Conference*, Vol. 8 of 1995 OSA Technical Digest Series (Optical Society of America, 1995), paper ThH2.
3. H. T. Hattori, and A. Safaai-Jazi, "Fiber designs with significantly reduced nonlinearity for very long distance transmission," *Appl. Opt.* **37**(15), 3190–3197 (1998).
4. C. Rasmussen, T. Fjelde, J. Bennike, F. Liu, S. Dey, B. Mikkelsen, P. Mamyshev, P. Serbe, P. van der Wagt, Y. Akasaka, D. Harris, D. Gapontsev, V. Ivshin, and P. Reeves-Hall, "DWDM 40G transmission over trans-pacific distance (10 000 km) using CSRZ-DPSK, enhanced FEC, and all-raman-amplified 100-km ultrawave fiber spans," *J. Lightwave Technol.* **22**(1), 203–207 (2004).
5. G. Charlet, J. Renaudier, H. Mardoyan, P. Tran, O. Bertran Pardo, F. Verluise, M. Achouche, A. Boutin, F. Blache, J. Dupuy, and S. Bigo, "Transmission of 16.4Tbit/s Capacity over 2,550km Using PDM QPSK Modulation Format and Coherent Receiver," in *National Fiber Optic Engineers Conference*, OSA Technical Digest (CD) (Optical Society of America, 2008), paper PDP3.
6. H. Masuda, E. Yamazaki, A. Sano, T. Yoshimatsu, T. Kobayashi, E. Yoshida, Y. Miyamoto, S. Matsuoka, Y. Takatori, M. Mizoguchi, K. Okada, K. Hagimoto, T. Yamada, and S. Kamei, "13.5-Tb/s (135 x 111-Gb/s/ch) No-Guard-Interval Coherent OFDM Transmission over 6,248 km Using SNR Maximized Second-Order DRA in the Extended L-Band," in *Optical Fiber Communication Conference*, OSA Technical Digest (CD) (Optical Society of America, 2009), paper PDPB5.
7. G. Charlet, M. Salsi, P. Tran, M. Bertolini, H. Mardoyan, J. Renaudier, O. Bertran-Pardo, and S. Bigo, "72x100Gb/s transmission over transoceanic distance, using large effective area fiber, hybrid raman-erbium amplification and coherent detection," in *Proc of OFC, San Diego, USA, 2009*, Paper PDPB6.
8. A. H. Gnauck, P. J. Winver, S. Chanrasekhar, X. Liu, B. Zhu, and D. W. Peckham, "10x224-gb/s WDM transmission of 28-G baud PDM 16-QAM on a 50-GHz Grid over 1,200 km of fiber," in *Proc of OFC 2010*, Paper PDPB8.

9. X. Zhou, J. Yu, M. Huang, Y. Shao, T. Wang, L. Nelson, P. Magill, M. Birk, P. I. Borel, D. W. Peckham, and R. Lingle, "64-Tb/s (640x107-Gb/s) PDM-36QAM transmission over 320 km using both pre- and post-transmission digital equalization," in Proc. of OFC 2010, Paper PDPB9.
10. J.-X. Cai, Y. Cai, C. R. Davidson, D. G. Foursa, A. Lucero, O. Sinkin, W. Patterson, A. Philipetskii, and N. S. And, Bergano, "Transmission of 96x100G pre-filtered PDM-RZ-QPSK channels with 300% spectral efficiency over 10,608 km and 400% spectral efficiency over 4,368 km," in Proc of OFC 2010, Paper PDPB10.
11. A. R. Chraplyvy, "Limitations on lightwave communications imposed by optical-fiber nonlinearities," J. Lightwave Technol. **8**(10), 1548–1557 (1990).
12. A. R. Chraplyvy, A. H. Gnauck, R. W. Tkach, and R. M. Derosier, "8 x 10 Gb/s transmission through 280 km of dispersion-managed fiber," IEEE Photon. Technol. Lett. **5**(10), 1233–1235 (1993).
13. A. H. Gnauck, G. Raybon, S. Chandrasekhar, J. Leuthold, C. Doerr, L. Stulz, A. Agarwal, S. Banerjee, D. Grosz, S. Hunsche, A. Kung, A. Marhelyuk, D. Maywar, M. Movassaghi, X. Liu, C. Xu, X. Wei, and D. M. Gill, "2.5 tb/s (64 x 42.7 Gb/s) transmission over 40 x 100 km NZDSF using RZ-DPSK format and all-Raman-amplified spans," in Proc. of OFC 2002, Paper PD-FC2.
14. T. Mizuochi, K. Ishida, T. Kobayashi, J. Abe, K. Kinjo, K. Motoshima, and K. Kasahara, "A comparative study of DPSK and OOK WDM transmission over transoceanic distances and their performance degradations due to nonlinear phase noise," J. Lightwave Technol. **21**(9), 1933–1943 (2003).
15. G. Charlet, N. Maaref, J. Renaudier, H. Mardoyan, P. Tran, and S. Bigo, "Transmission of 40Gb/s QPSK with coherent detection over ultra-long distance improved by nonlinearity mitigation," in Proc. Eur. Conf. Opt. Commun. 2006.
16. F. Yaman and G. Li, "Nonlinear impairment compensation for polarization-division multiplexed WDM transmission using digital backward propagation," IEEE Photonics Journal **1**(2), 144–152 (2009).
17. R.-J. Essiambre, B. Mikkelsen, and G. Raybon, "Intra-channel cross-phase modulation and four-wave mixing in high-speed TDM systems," Electron. Lett. **35**(18), 1576–1578 (1999).
18. P. V. Mamyshev, and N. A. Mamysheva, "Pulse-overlapped dispersion-managed data transmission and intrachannel four-wave mixing," Opt. Lett. **24**(21), 1454–1456 (1999).
19. M.-J. Li, and D. A. Nolan, "Optical transmission fiber design evolution," J. Lightwave Technol. **26**(9), 1079–1092 (2008).
20. Z. Haas, and M. A. Santoro, "A mode-filtering scheme for improvement of the bandwidth-distance product in multimode fiber systems," J. Lightwave Technol. **11**(7), 1125–1131 (1993).
21. D. H. Sim, Y. Takushima, and Y. C. Chung, "High-speed multimode fiber transmission by using mode-field matched center-launching technique," J. Lightwave Technol. **27**(8), 1018–1026 (2009).
22. Z. Tong, Q. Yang, Y. Ma, and W. Shieh, "21.4 Gbit/s transmission over 200 km multimode fiber using coherent optical OFDM," Electron. Lett. **44**(23), 1373–1374 (2008).
23. W. Shieh, "OFDM for adaptive ultrahigh-speed optical networks," Optical Fiber Communication Conference National Fiber Optic Engineers Conference OFC-NFOEC'2010, paper OWO1, San Diego, California, USA, 2010.
24. P. Pepeljugoski, D. Kuchta, Y. Kwark, P. Pleunis, and G. Kuyt, "15.6-Gb/s transmission over 1 km of next generation multimode fiber," IEEE Photon. Technol. Lett. **14**(5), 717–719 (2002).
25. P. Pepeljugoski, M. J. Hackert, J. S. Abbott, S. E. Swanson, S. E. Golowich, A. J. Ritger, P. Kolesar, Y. C. Chen, and P. Pleunis, "Development of system specification for laser-optimized 50- μ m multimode fiber for multigigabit short-wavelength LANs," J. Lightwave Technol. **21**(5), 1256–1275 (2003).
26. L. G. Cohen, and S. D. Personick, "Length dependence of pulse dispersion in a long multimode optical fiber," Appl. Opt. **14**(6), 1357–1360 (1975).
27. K. Kitayama, S. Seikai, and N. Uchida, "Impulse response prediction based on experimental mode coupling coefficient in a 10-km long graded-index fiber," IEEE J. Quantum Electron. **16**(3), 356–362 (1980).
28. R. Olshansky, "Mode coupling effects in graded-index optical fibers," Appl. Opt. **14**(4), 935–945 (1975).
29. N. Lagakos, J. H. Cole, and J. A. Bucaro, "Microbend fiber-optic sensor," Appl. Opt. **26**(11), 2171–2180 (1987).
30. D. Donlagic, and B. Culshaw, "Microbend sensor structure for use in distributed and quasi-distributed sensor systems based on selective launching and filtering of the modes in graded index multimode fiber," J. Lightwave Technol. **17**(10), 1856–1868 (1999).
31. D. Donlagic, "A low bending loss multimode fiber transmission system," Opt. Express **17**(24), 22081–22095 (2009).
32. N. Shibata, M. Tateda, S. Seikai, and N. Uchida, "Spatial technique for measuring modal delay differences in a dual-mode optical fiber," Appl. Opt. **19**(9), 1489–1492 (1980).
33. C. Emslie, "Polarization maintaining fibers," in *Specialty Optical Fibers Handbook*, A. Méndez and T.F. Morse, eds. (Academic, 2007), pp. 243–277.
34. M. Faucher, and Y. K. Lizé, "Mode field adaptation for high power fiber lasers," Conference on Lasers and Electro-Optics, 2007, Paper CF17.
35. S. Ramachandran, J. W. Nicholson, S. Ghalmi, M. F. Yan, P. Wisk, E. Monberg, and F. V. Dimarcello, "Light propagation with ultralarge modal areas in optical fibers," Opt. Lett. **31**(12), 1797–1799 (2006).
36. M. G. Taylor, "Coherent detection method using DSP for demodulation of signal and subsequent equalization of propagation impairments," IEEE Photon. Technol. Lett. **16**(2), 674–676 (2004).

Capacity of long-haul optical transmission systems have been increasing at a rate exceeding the Moore's Law. However, the demand for higher bandwidth has been increasing even faster. Fiber capacity can be increased by reducing the fiber loss, or increasing the OSNR, reducing the channel spacing, increasing the low loss window to fit more WDM channels, or making better use of the existing window by employing higher order modulation formats [1]. All of these choices face several technical issues, and a common underlying limitation is fiber nonlinearity. Alleviating the ASE noise as well as using higher modulation formats such as M-QAM requires higher OSNR, which in turn requires higher signal power and therefore leads to higher nonlinearity. Reducing the channel spacing and increasing the number of channels by expanding the low loss window increases inter channel nonlinearities. It is clear that reducing the fiber nonlinearity would allow increasing the fiber capacity in several dimensions depending on which methods are technically more viable. One promising way to deal with fiber nonlinearities is to increase the fiber core diameter and as a result decrease the fiber nonlinearity [2,3]. Indeed, most of the recent record breaking transmission systems have used larger and larger effective area fibers for transmission [4–10]. However, as the fiber core diameter is increased the fiber becomes multimode. So far all the large core area fibers were designed to be single mode and therefore their core diameters remained limited by the single-mode condition. In this paper we propose and demonstrate for the first time that fiber core diameter can be increased beyond the limitation of the single-mode condition and they can be used for long-haul transmission even though they can support several spatial modes. It is also demonstrated with an experiment that this can be achieved with no penalty due to modal dispersion or excess loss, providing single-mode fiber performance with the low nonlinearity advantage of multimode fiber.

The limitations of fiber nonlinearity became clear early on with the introduction of WDM [11] and there have been significant efforts to reduce, mitigate or remove nonlinear penalties since then. Using dispersion maps [12], more nonlinearity tolerant modulation formats such as DPSK [13,14], or amplification schemes such as Raman amplification [14], designing fibers with large effective area [2,3], and recently compensating nonlinear impairments using digital signal processing (DSP) techniques [15,16] are among the methods used. All these methods are limited in the extent that they can reduce the nonlinear impairments. Employing large dispersion fibers and maps help with inter-channel nonlinearities but eventually they increase intra-channel nonlinearities [17,18]. DSP techniques require a significant amount of computation and cannot compensate nonlinear impairments completely because of ASE noise coupling through nonlinearity [16]. Increasing the core size on the other hand can reduce the fiber nonlinearity directly and dramatically. It can also be used in tandem with the aforementioned mitigation techniques, to reduce the nonlinear impairments even further.

In the late seventies, multimode fibers were the fiber of choice because of the ease of coupling LEDs to them and also because they were more tolerant to connection and splice losses [19]. Using multimode fibers for long-haul transmission was abandoned because modal dispersion caused by the large group delay between different spatial modes. However, modal dispersion only happens if a channel is carried in different spatial modes. If only one mode is excited and all the signal power remains in this mode there is no modal dispersion. This principle of utilizing only a single mode of the multimode fiber, also known as the single-mode operation, has been used by several groups to achieve capacities beyond the bandwidth distance product [20,21]. However such efforts have been limited to short distances. In addition, optical orthogonal frequency-division multiplexing (OFDM) has been suggested as a way of providing tolerance to modal dispersion [22]. The OFDM approach to transmission in multimode fiber inherently assumed that modal dispersion will be present in all multimode fibers regardless the number of modes supported by the fiber [23].

Single-mode operation is based on exciting only one mode of the multimode fiber typically by splicing a single-mode fiber to the multimode fiber and splicing another single-mode fiber at the end to collect only the excited mode. The reason that this method worked

only at short distances was because the multimode fibers used in these efforts was standard multimode fibers (SMMF)s. SMMFs are designed with criteria that are very different from criteria used for single-mode fibers. SMMFs should be easy to handle, inexpensive to manufacture, and they should efficiently collect light from inexpensive but low beam quality laser diodes [19]. As a result these fibers have very large core areas, and also very large numerical apertures (NA). Therefore these fibers support hundreds of modes. Moreover since it is taken for granted that modal dispersion will be there, these fibers are designed so that all of the spatial modes have similar propagation properties to reduce the modal dispersion [24,25]. Since modal dispersion has a square root dependence rather than linear dependence on the fiber length when the spatial modes couple efficiently these fibers are designed in such a way that modal coupling is enhanced [26,27]. Therefore, the distances achieved by using the single-mode operation have been limited because even though a single-mode is excited at the start of the fiber, this mode couples to other modes causing excess loss, and also as the other modes couple back to the initially excited mode, modal dispersion occurs.

It is encouraging that even with SMMFs several groups were able to transmit bit rates at 10 Gb/s or more, to distances on the order of several kilometers with negligible or no dispersion penalty [22]. By using multimode fibers that are optimized for reducing mode coupling rather than increasing it, it should be possible to extend the modal-dispersion-free transmission distance. The critical question is that, for modern long-haul transmission systems reaching several thousands of kilometers, how far this penalty-free distance could be extended? It is adequate to extend this distance only up to typical span lengths or even less, which is of the order of only several tens of kilometers. Once such lengths are achieved without inducing modal dispersion it is easy to cascade such spans to make long-haul transmission systems. Since single-mode operation requires basically pigtailed the multimode fiber at each end by single-mode fibers, these fibers can be easily incorporated with the rest of the transmission systems through the single-mode pigtails. The advantage of using the single-mode operation is that using multimode fiber as the transmission fiber does not require redesigning the rest of the transmission system to accommodate the same modes as the transmission fiber. Note that, the entire span does not have to be completely multimode fiber. If the penalty-free distance cannot be extended so far as to cover the entire span length, they can be spliced to regular single-mode fibers which can cover the rest of the span. By using the multimode fiber at the beginning of the span right after the amplifiers where the power is high, and using single-mode fibers where the power is low significant reductions in nonlinear impairments can still be achieved.

The most straight forward way to reduce mode coupling is to make sure that the supported modes have propagation properties, especially propagation constants, as different as possible. It is well known that as the difference between the propagation constants of two modes increases the coupling between these modes reduces dramatically [28–31]. The simplest way to increase the index difference between different modes is to reduce the number of modes. Therefore as a first step we propose and demonstrate using few-mode fibers (FMFs) rather than SMMFs in single-mode operation as transmission fibers in each span for long distance transmission.

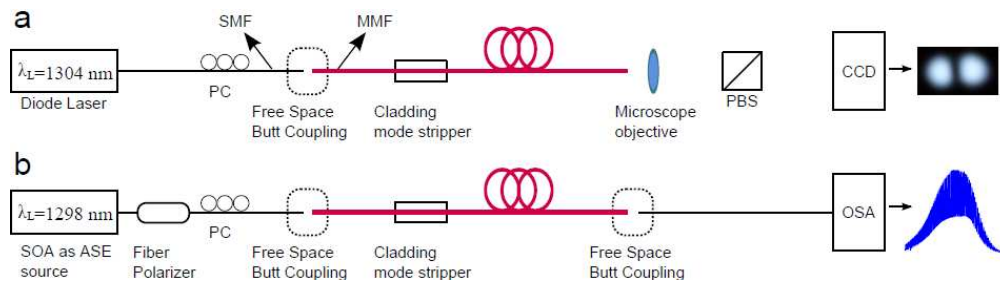

Fig. 1. a) Setup used for imaging the higher-order modes supported by the few-mode fiber. b) Setup used for measuring the phase delay between the two spatial modes supported by the few-mode fiber. PC: polarization controller, PBS: polarizing beam splitter, SOA: semiconductor optical amplifier, OSA: optical spectrum analyzer

Since few-mode fibers with losses compatible with long-distance propagation are not readily available, a large-mode area but still single-mode fiber at 1550 nm is used. The fiber has a cut off wavelength close to 1.5 μm , therefore it is dual mode at 1310 nm. This fiber is used at 1310 nm in the long-haul transmission experiment. The fiber is 35 km long, it has a loss coefficient of 0.2 dB/km, and mode-field diameter of 11 μm at 1550 nm.

The first step is to establish that the fiber indeed supports a few modes at 1310 nm by directly imaging the higher-order modes if there are any. The setup shown in Fig. 1a is used to isolate and image the higher-order modes [32]. In the setup, a continuous wave (CW) laser at 1304 nm is used as the source. After the polarization controller the light is launched from the single-mode fiber (SMF) into the FMF, using free-space butt coupling. Splicing was not used because even with misaligned splicing, the excited light was predominantly in the fundamental mode. With free space coupling, the SMF is offset from the center of the FMF by a few microns and higher-order modes were excited efficiently. At the input end of the FMF, a cladding mode stripper is inserted to make sure that cladding modes are not excited. The cladding mode stripper was obtained by removing the plastic coating of the fiber from a 10-cm long section, placing the bare fiber on a microscope slide, bending it by several degrees and pouring index matching gel on the bare fiber with a refractive index of 1.64. Placing the cladding mode stripper did not make any difference in the measurements. Output of the 100-m-long FMF is imaged to a CCD camera through a polarizer. The polarization controller following the diode laser is adjusted so that the fundamental mode is completely blocked by the polarizer. As expected the distinct two-lobe intensity profile of the LP_{11} mode was clearly observed as shown in Fig. 2a confirming the multimode nature of the fiber. Adjusting the input polarization and the launching offset it was possible to obtain both the even and odd modes of the LP_{11} mode. However no higher order mode is observed.

The next step was to verify whether this fiber has an extraordinarily large effective index difference between the supported modes. The setup shown in Fig. 1b was used to measure the effective index difference between the two spatial modes. In this setup a semiconductor optical amplifier (SOA) is used as an ASE source centered at 1298 nm. After the polarizer and the polarization controller, the broadband light is coupled from the SMF to FMF through free-space butt coupling with an optimized offset as before. After passing through the 10-m-long FMF in two distinct spatial modes and therefore with two different phase velocities, the output of the fiber is coupled back to a single-mode fiber and the output spectrum was measured by an optical spectrum analyzer. The spectrum of the ASE source before the FMF (red line) and the fringes produced by the coherent beating of the two modes (blue line) are shown in Fig. 2b. The source of the fringes is verified to be the multi-path interference between the two modes by replacing the 10-m-long fiber with a 100-m-long fiber. As expected, the fringe spacing scales inversely with the fiber length. It is also verified that these fringes do not originate from cladding modes by using cladding mode stripper. Based on the fringe period, the delay between the two modes is found to be 470 ps/km corresponding to an effective

index difference of $\delta n = 1.4 \times 10^{-4}$. With this index difference the beat length is 9.2 mm. To put this value in perspective, note that polarization maintaining fibers which are designed to eliminate the coupling between the two polarization modes typically have beat lengths in the several millimeters length scale [33].

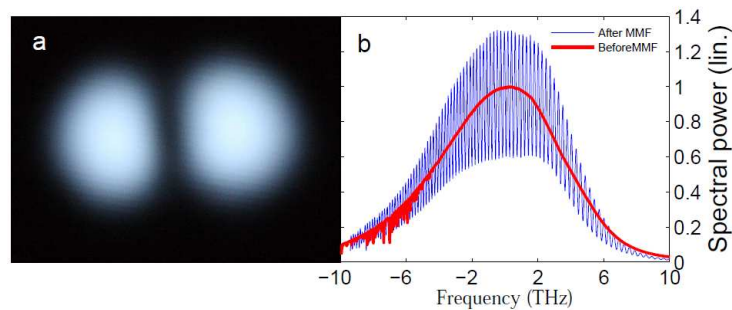

Fig. 2. a) Intensity profile of the LP_{11} mode captured by the CCD. b) Optical spectrum measured by the OSA in Fig. 1b before (red, thick line) and after (blue, thin line) the few-mode fiber. The vertical scale is in arbitrary linear units.

To verify that this FMF can be used for optical transmission, the 35-km-long fiber was spliced to SMF fibers at both ends. Splicing was performed using a standard Fujikura 30S splicer. The default SMF-to-SMF splicing mode is used. No special procedures such as long arc times or tapering are used. As a first check, the insertion loss of the fiber is measured. With this setup the fundamental mode of the FMF is easily excited. If at the launching point the LP_{11} mode is also excited, or if there is mode coupling along the fiber, the LP_{11} mode should be mostly filtered out at the output splice resulting in excess loss. After splicing the fibers, the insertion loss is measured to be 11.9 dB including the connector losses, the splice losses from the single mode patches to the single-mode pigtails and finally the splice losses between the SMF pigtails and the FMF. All the SMF fibers and patches are standard single-mode fibers. Noting that at 1310 nm SMF fibers typically have losses between 0.33- 0.35 dB/km resulting in a total loss between 11.55 dB and 12.25 dB after 35 km, it is safe to conclude that the FMF fiber does not have excess loss. The lack of excess loss is very crucial for confirming the lack of mode coupling since in the presence of mode coupling it is almost impossible to avoid excess loss.

The core diameters of the SMF and the FMF are approximately 9 μm and 11 μm , resulting in low splicing loss obtained. This is not surprising because efficient coupling from SMF fibers to large core area fibers with diameter ratios up to 2 or 3 times are routinely achieved by using slightly more involved procedures still achievable by standard fusion splicers [34]. More sophisticated techniques are also available such as fiber gratings to efficiently couple light from SMF fibers to higher order modes of multimode fibers and back if desired [35].

The final confirmation of the lack of mode coupling comes from the lack of modal dispersion, in other terms lack of modal-dispersion impairments after propagation through the fiber. This point is confirmed using the set up shown in Fig. 3, where the pigtailed FMF is connected to a single channel transmitter at one end and a coherent receiver at the other end. The details of the transmitter and the receiver are discussed below and shown in Fig. 5. The transmitted data is a single channel BPSK modulation at 1307 nm. Modulation rate is 6 Gb/s and the pseudo random bit pattern is $2^{23}-1$ bits long.

Figure 4a and 4b show the eye diagram obtained back-to-back, and after 35 km of FMF, respectively. The Q value remained virtually the same after transmission at approximately 18.6 dB verifying that no modal dispersion is observed. Together with the lack of excess loss, this result proves that no mode coupling occurred during the transmission. In Fig. 4, the eye diagram is plotted before the matched ASE filter is applied so that the waveform and any impairment suffered by the waveform are directly visible.

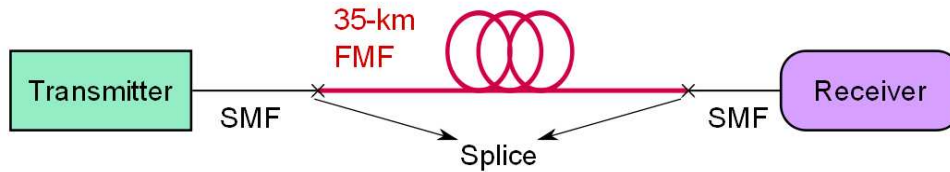

Fig. 3. Experimental setup for transmitting single channel 6 Gb/s BPSK data through 35-km long FMF.

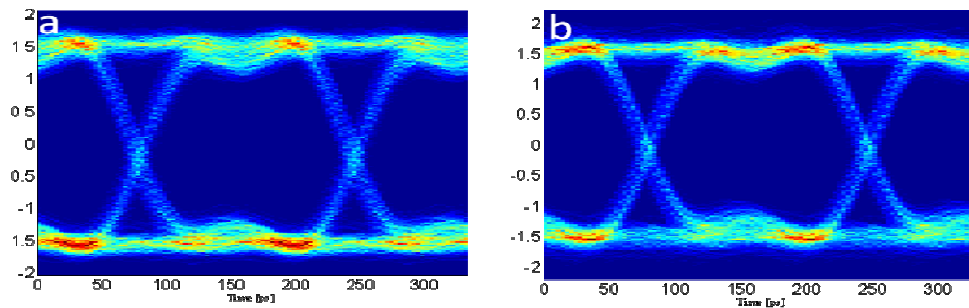

Fig. 4. (a) Back-to-back eye diagram with $Q = 18.4$ dB and (b) eye diagram after 35 km with $Q = 18.6$ dB.

Once it is established that signals can be transmitted with no penalties through one span it is obvious that long-haul transmission is possible simply by concatenating such spans with amplification in between to balance the loss. The setup in Fig. 5 shows the setup used to verify such a long-haul transmission. The transmitter consists of three WDM BPSK channels centered at 1307 nm with a bit rate of 6 Gb/s and channel spacing of 25 GHz. All the channels carry the same pseudo random bit sequence of length $2^{23}-1$, but the center channel is delayed from the rest by several bit periods. After all the WDM channels are aligned to the same polarization and same average power, they are combined and amplified by a semiconductor optical amplifier (SOA) before they are launched into the loop.

The loop consists of the 35-km-long FMF with the SMF pigtails, followed by an SOA to balance the loop loss, then a 10-nm-wide band-pass filter and a polarization controller. Loop switching is obtained by acousto-optic modulators with a 3 dB insertion loss. Total power at the input of the FMF is -3 dBm. The total loop loss including the fiber is approximately 22 dB.

After the loop, the signal is mixed in a 90-degree hybrid with a local oscillator which is tuned to the center channel wavelength. The two quadratures are detected by fast photodetectors. The output of the photodetectors are amplified by linear amplifiers and sampled at 40 Gsa/s using a real time oscilloscope with 12 GHz analog bandwidth. The recorded data is transferred to a computer for processing. The digital processing consists of chromatic dispersion compensation, phase estimation, and linear matched filtering to reduce the ASE noise [16,36]. Note that no signal processing is used or required to remove the modal dispersion.

Figure 6a and 6b show the eye diagrams for the central channel before and after propagating 30 loops corresponding to a total length of 1050 km. The Q value dropped from its back-to-back value of 21 dB to 16 dB after 1050 km. Because the eye diagrams are plotted after the matched ASE filters, the Q value is larger and the eye diagrams look different compared to the eye diagrams after single span showed in Fig. 4.

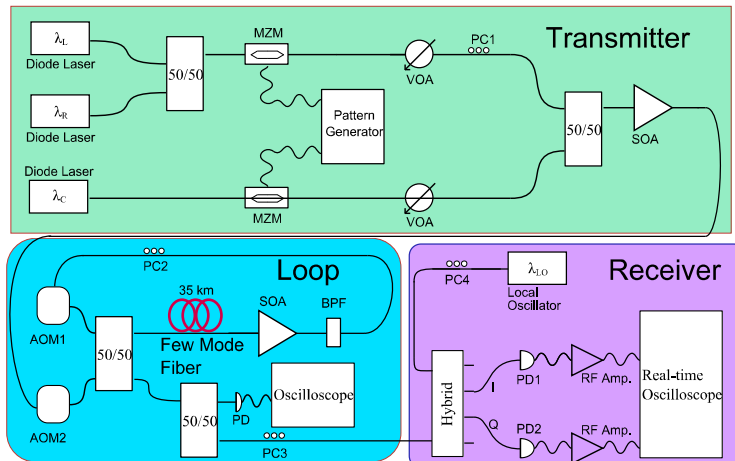

Fig. 5. Experimental setup for WDM transmission in few-mode fiber. The 35-km-long few-mode fiber is spliced to SMF on both ends and it is the only multimode element in the setup. SOA: semiconductor optical amplifier, PC: polarization controller, AOM: acousto-optic modulator.

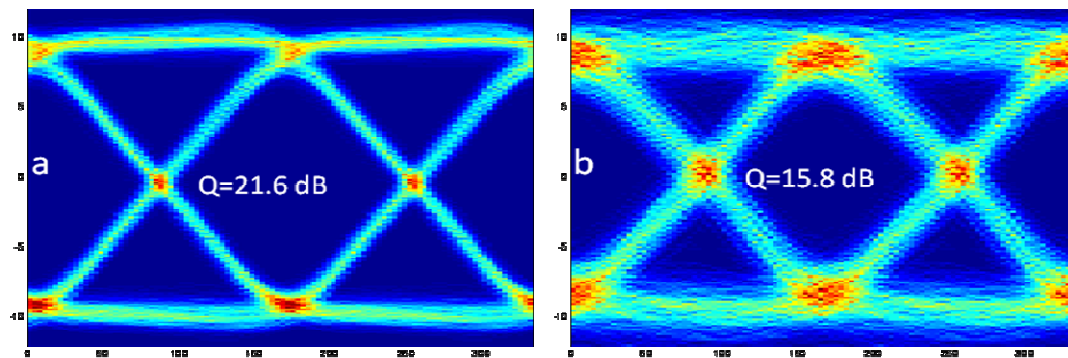

Fig. 6. (a) Back-to-back eye diagram with $Q = 21.6$ dB and (b) eye diagram after 1050 km with $Q = 15.8$ dB.

The drop in the Q value is mostly due to additive ASE noise as a result of the high loop loss and lack of proper ASE filters. OSNR on the other hand is limited by the SOA nonlinearity. Because SOA nonlinearity dominates over fiber nonlinearity, the improvement in the nonlinearity could not be measured directly. No modal dispersion was observed, either in the received optical field or in the received optical spectrum. Note that even though the bit rate is low, it is still large enough to show the impairments resulting from modal dispersion. On the other hand the low bit rate allowed us to overcome the ASE noise and show clear eye opening after 1000 km so that any impairment resulting from modal dispersion could be seen clearly.

In conclusion we have shown that few-mode fibers can be used for long-distance transmission without modal dispersion or insertion loss penalty. In particular the experimental results show that no mode coupling is observed in 35-km-long few-mode fiber and after 1050 km of transmission in a recirculating loop. It should be noted that the FMF length of 35 km is much longer than the nonlinear length of the fiber. Nonlinearity tolerance of transmission systems using few-mode fibers is expected to increase because of the large effective area.