



US008174647B2

(12) **United States Patent**
Ge et al.

(10) **Patent No.:** **US 8,174,647 B2**
(45) **Date of Patent:** **May 8, 2012**

(54) **TRANSFLECTIVE LIQUID CRYSTAL DISPLAY COMPRISING A DIELECTRIC LAYER BETWEEN THE FIRST AND SECOND ELECTRODES IN THE TRANSMISSIVE REGION**

(75) Inventors: **Zhibing Ge**, Orlando, FL (US); **Xinyu Zhu**, Orlando, FL (US); **Thomas Xinzhang Wu**, Orlando, FL (US); **Shin-Tson Wu**, Orlando, FL (US); **Wang-Yang Li**, Tainan County (TW); **Chung-Kuang Wei**, Taipei (TW)

(73) Assignees: **Chimei Innolux Corporation**, Miaoli County (TW); **University of Central Florida Research Foundation, Inc.**, Orlando, FL (US)

(*) Notice: Subject to any disclaimer, the term of this patent is extended or adjusted under 35 U.S.C. 154(b) by 0 days.

(21) Appl. No.: **12/899,792**

(22) Filed: **Oct. 7, 2010**

(65) **Prior Publication Data**

US 2011/0019137 A1 Jan. 27, 2011

Related U.S. Application Data

(62) Division of application No. 11/678,691, filed on Feb. 26, 2007, now abandoned.

(51) **Int. Cl.**
G02F 1/1335 (2006.01)

(52) **U.S. Cl.** **349/114**

(58) **Field of Classification Search** 349/114
See application file for complete search history.

(56) **References Cited**

U.S. PATENT DOCUMENTS

5,986,730 A 11/1999 Hansen et al.
6,341,002 B1 1/2002 Shimizu et al.
6,977,702 B2 12/2005 Wu

7,015,997 B2 3/2006 Choi et al.
2002/0036730 A1 3/2002 Baek et al. 349/106
2003/0048395 A1* 3/2003 Yasui 349/43
2003/0095217 A1* 5/2003 Sakamoto et al. 349/106
2003/0210369 A1 11/2003 Wu 349/114
2004/0218123 A1 11/2004 Park et al. 349/114
2005/0122450 A1 6/2005 Kang 349/114
2006/0103792 A1* 5/2006 Lee et al. 349/113
2006/0187371 A1* 8/2006 Nakayoshi et al. 349/38

OTHER PUBLICATIONS

S. Pancharatnam, "Achromatic Combinations of Birefringent Plates: Part I, An Achromatic Circular Polarizer," in Proceedings of the Indian Academy of Sciences, vol. 41, sec. A, 1955, pp. 130-136.

X. Zhu et al, "Analytical Solutions for Uniaxial-Film-Compensated Wide-View Liquid Crystal Displays," Journal of Display Technology, vol. 2, No. 1, pp. 2-20, Mar. 2006.

* cited by examiner

Primary Examiner — Mark Robinson

Assistant Examiner — Dennis Y. Kim

(74) *Attorney, Agent, or Firm* — Fish & Richardson P.C.

(57) **ABSTRACT**

A display includes a plurality of pixel circuits, each pixel circuit including a first electrode, a second electrode, a reflective region, and a transmissive region. The reflective region reflects ambient light and includes a first portion of a liquid crystal layer and a polarization dependent reflector. The transmissive region transmits backlight and includes a second portion of the liquid crystal layer. A dielectric layer is between the first and second electrodes in one of the reflective region and the transmissive region, the dielectric layer configured such that when a pixel voltage is applied to the first and second electrodes, the percentage of the pixel voltage applied across the first portion of the liquid crystal layer is different from the percentage of the pixel voltage applied across the second portion of the liquid crystal layer. The display includes a backlight module to generate the backlight.

19 Claims, 19 Drawing Sheets

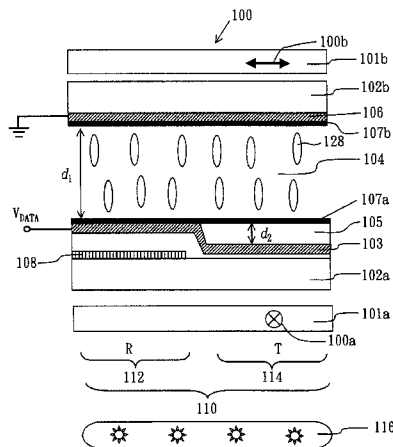

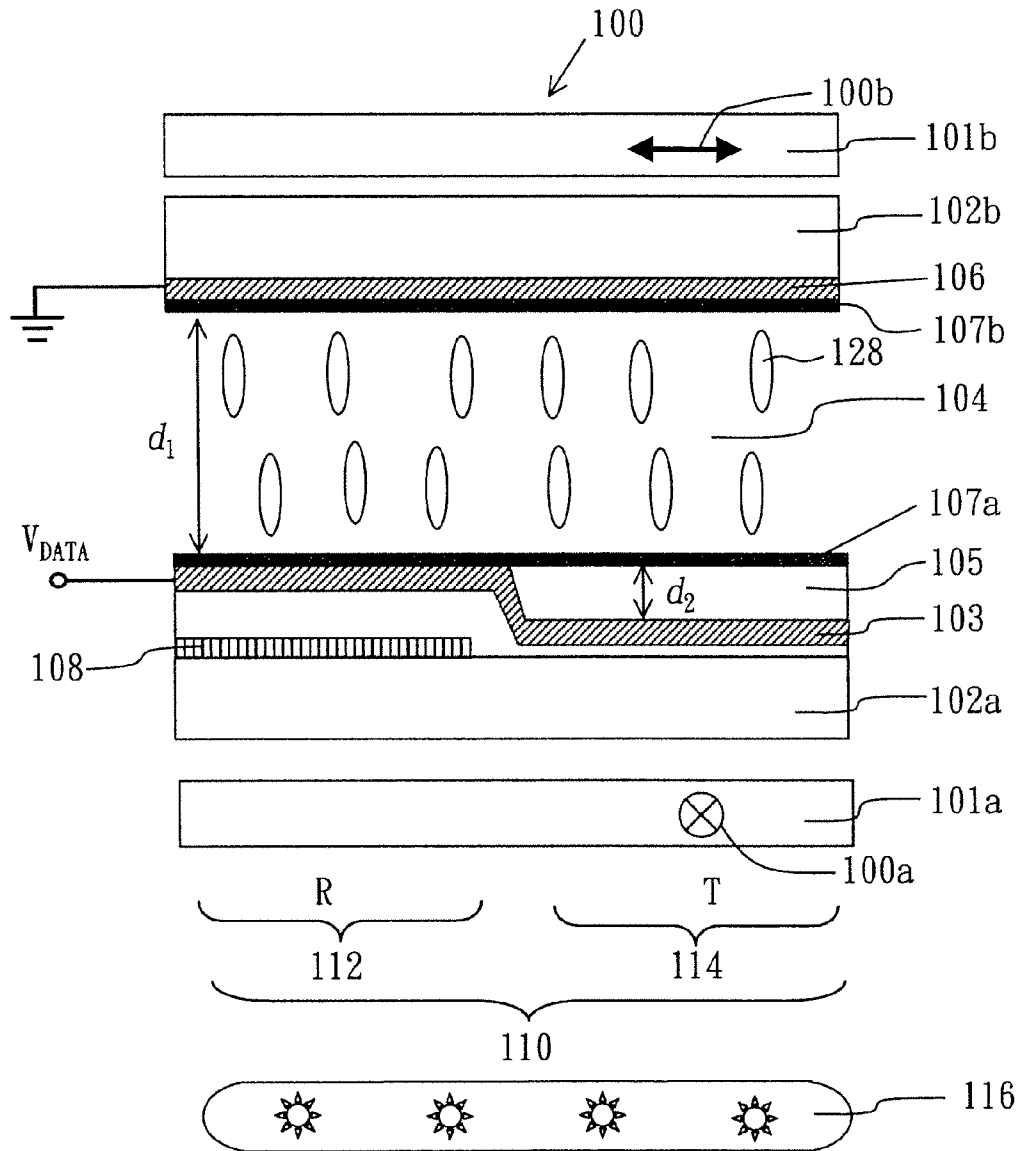

FIG. 1

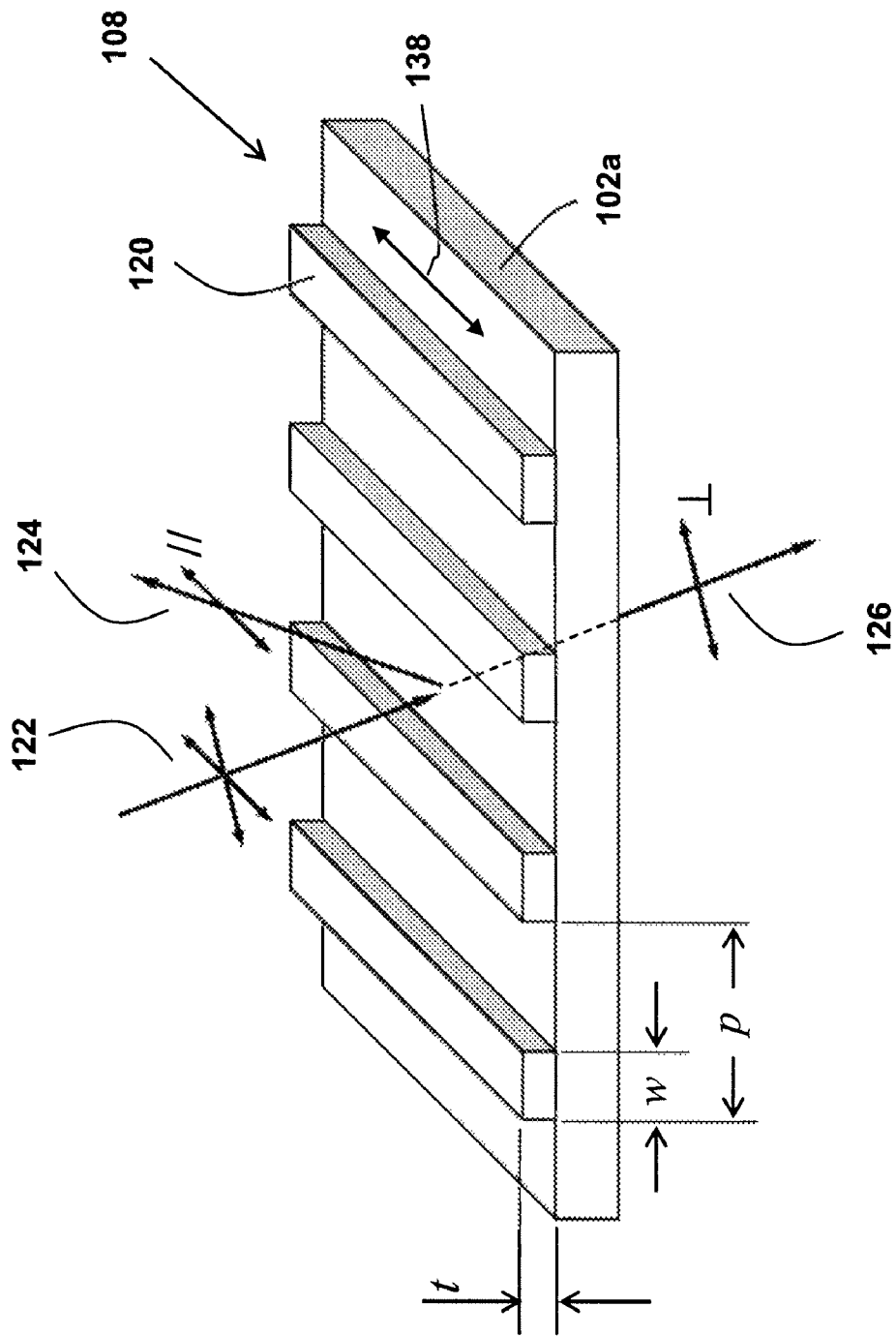

FIG. 2

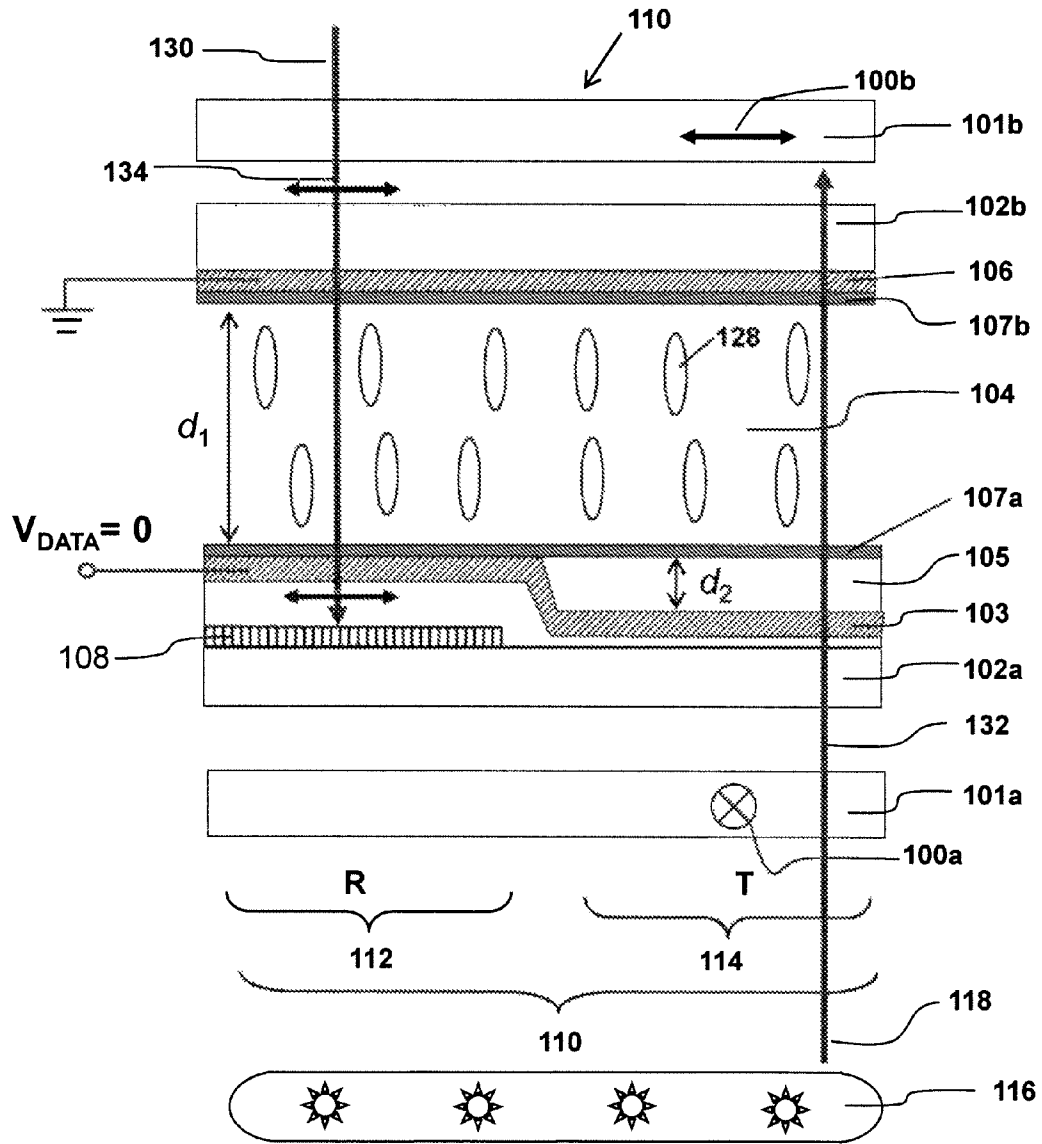

FIG. 3A

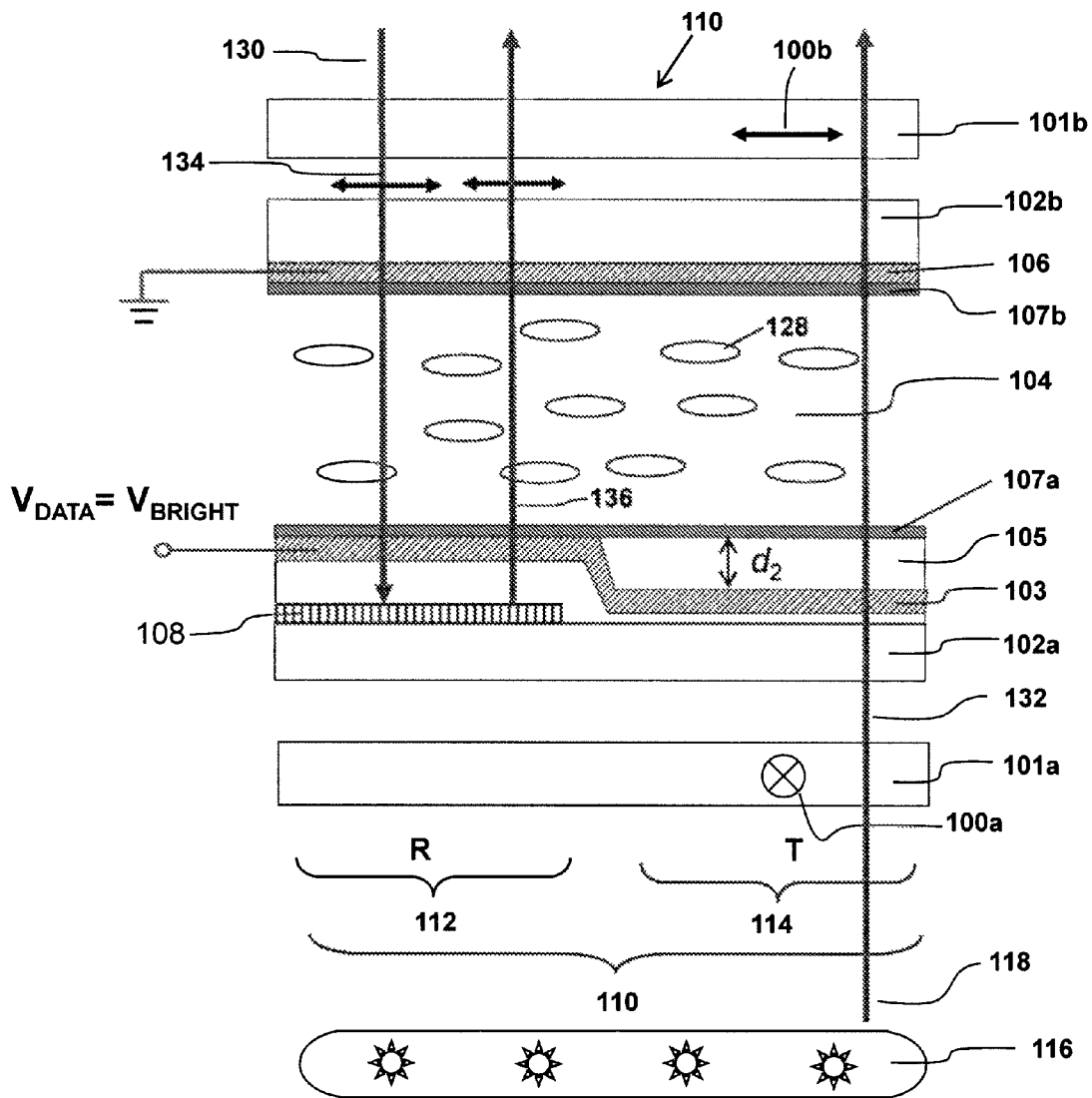

FIG. 3B

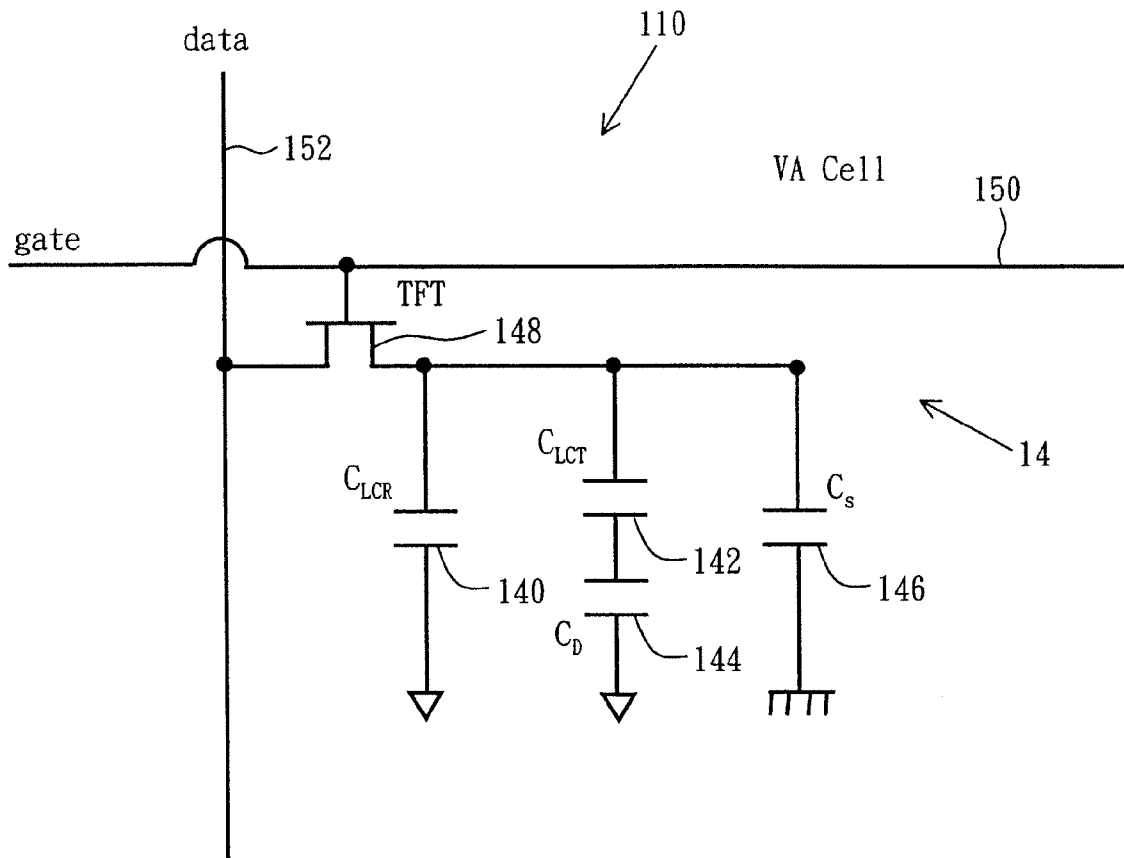

FIG. 4

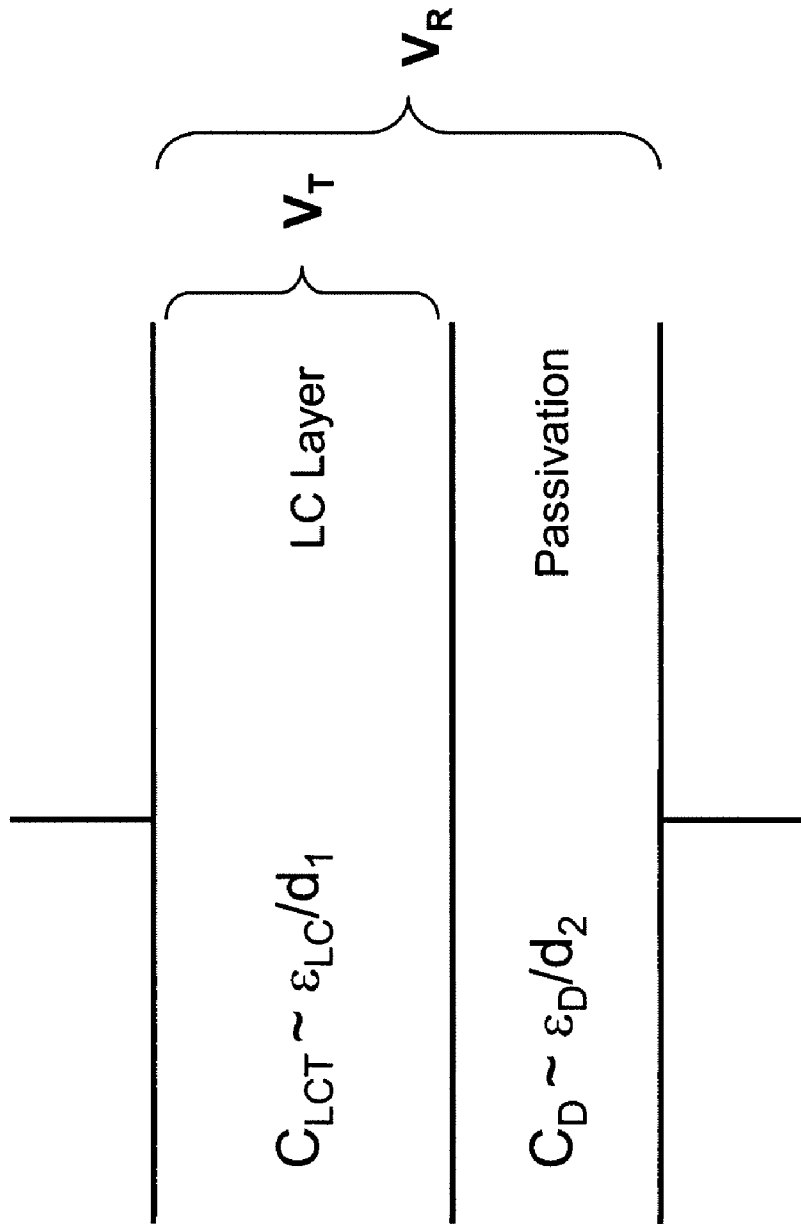

FIG. 5

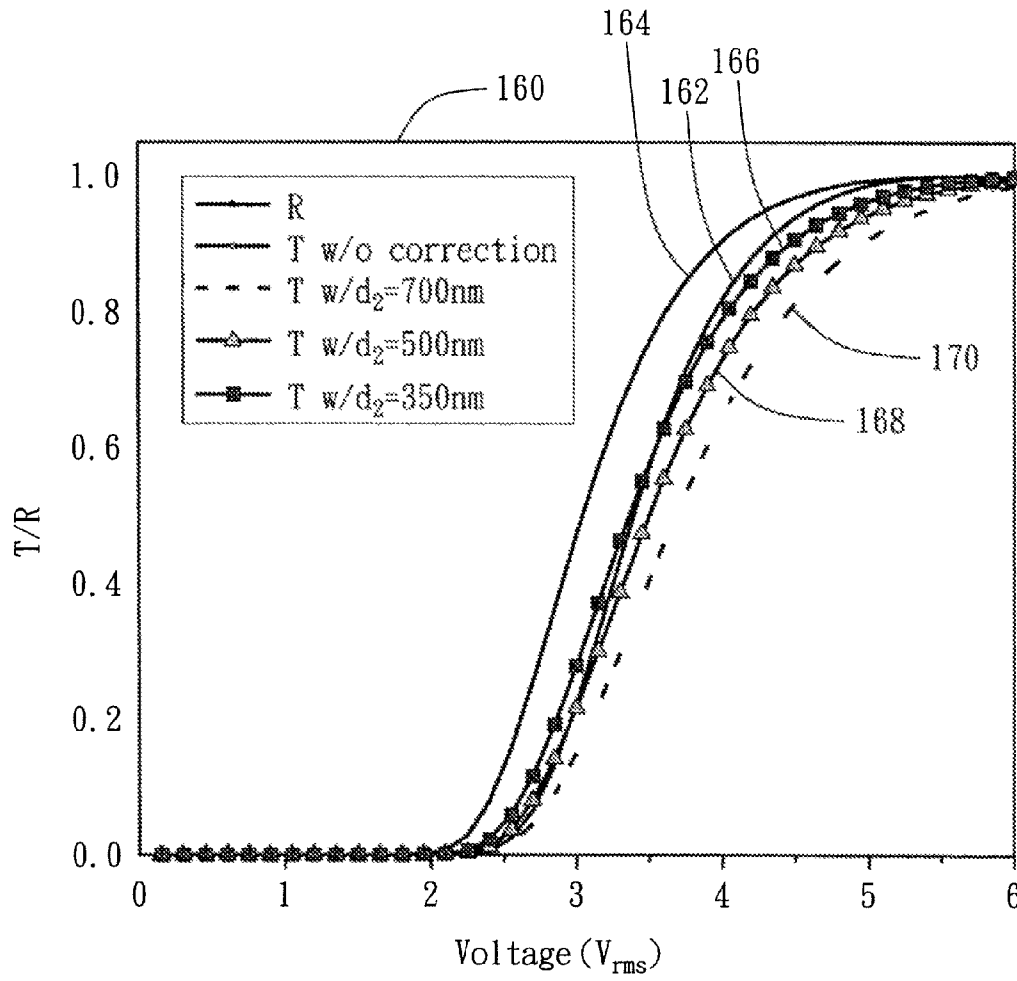

FIG. 6

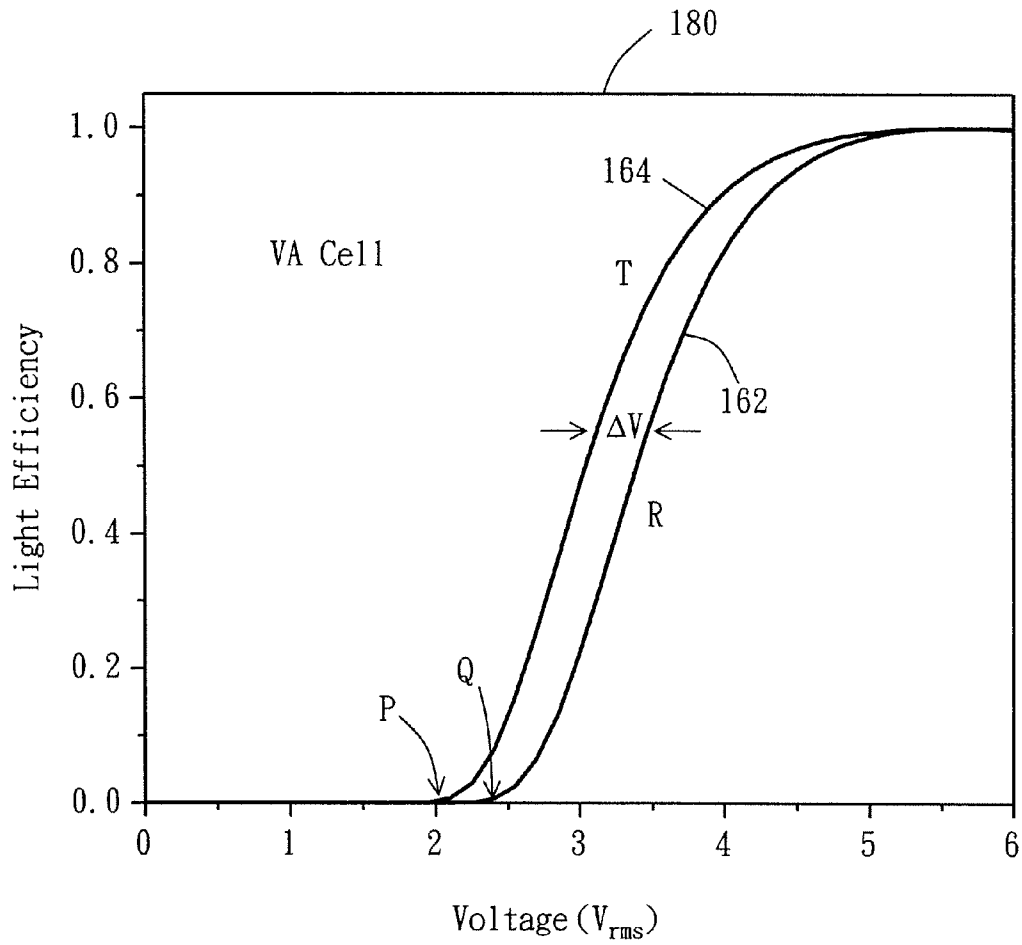

FIG. 7

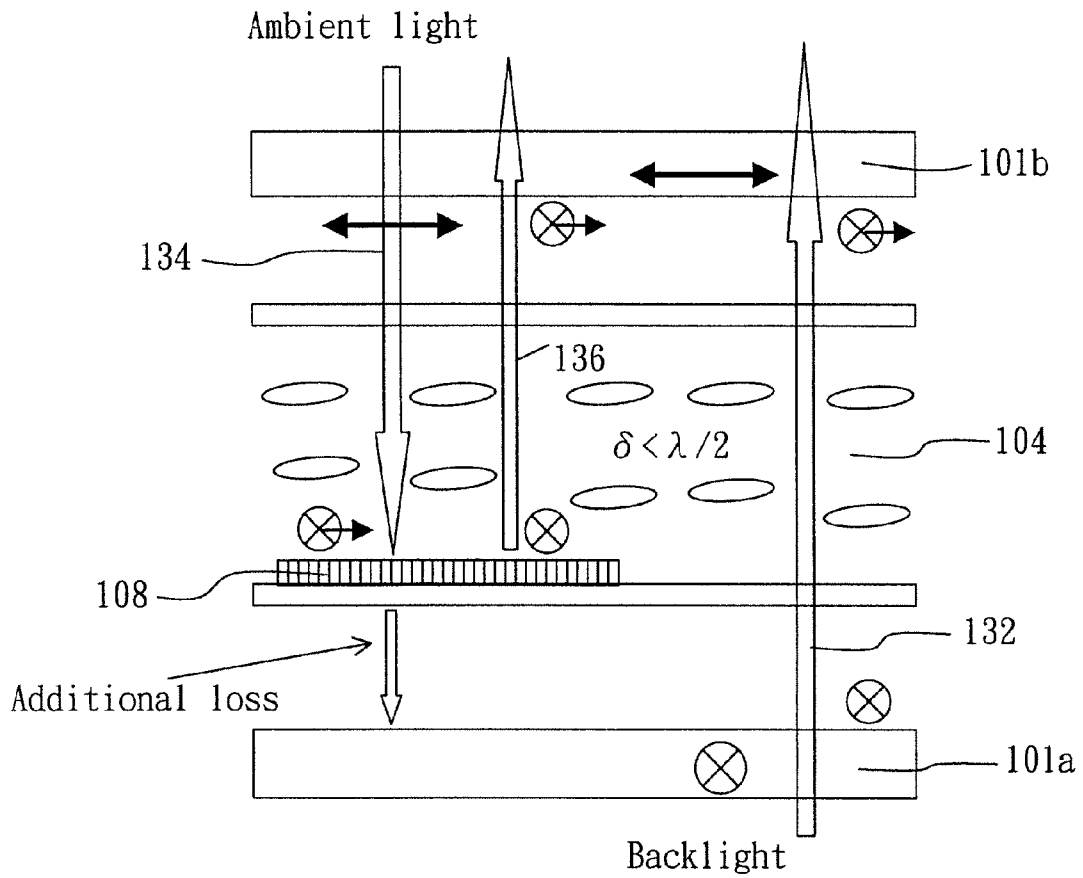

FIG. 8

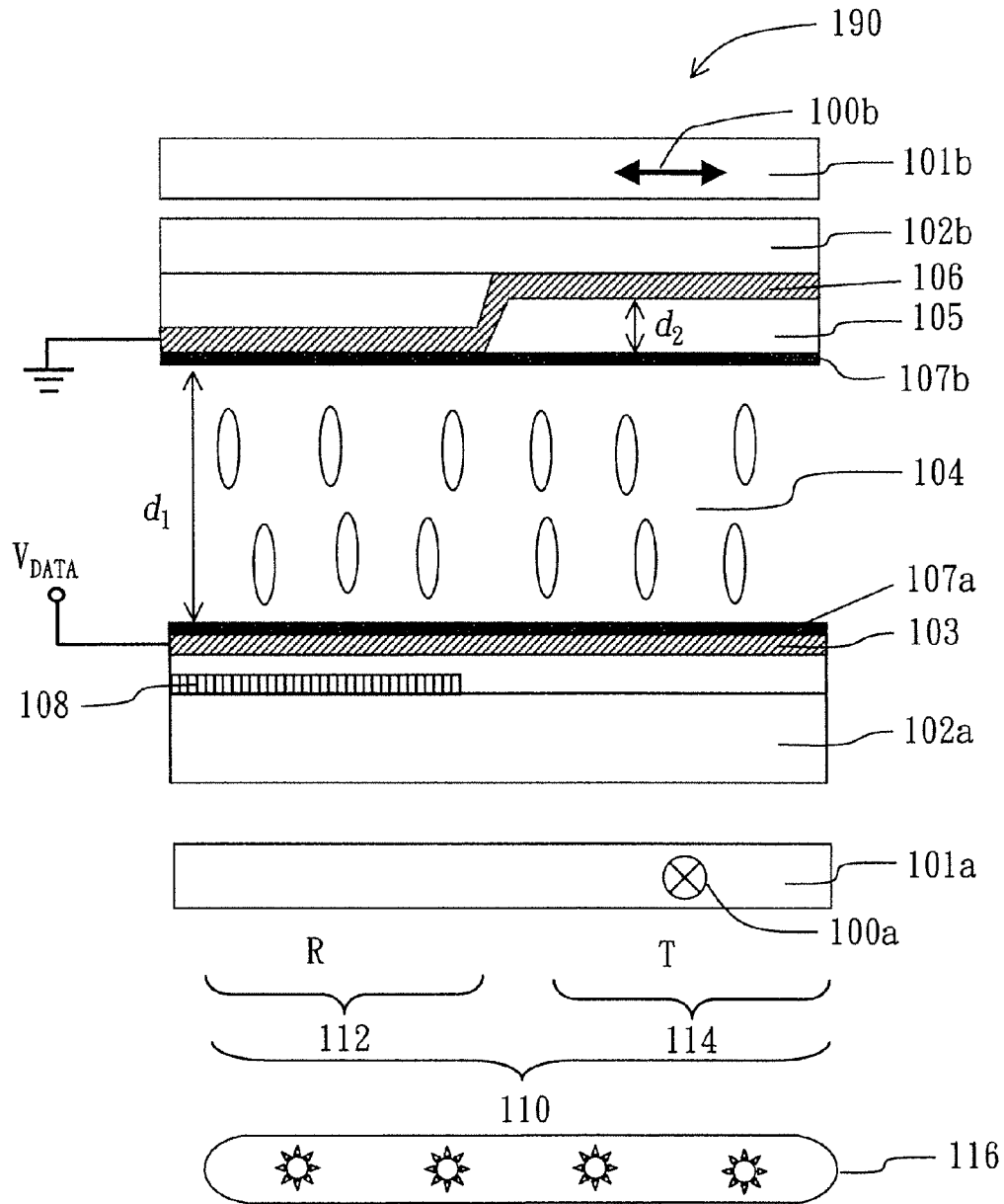

FIG. 9

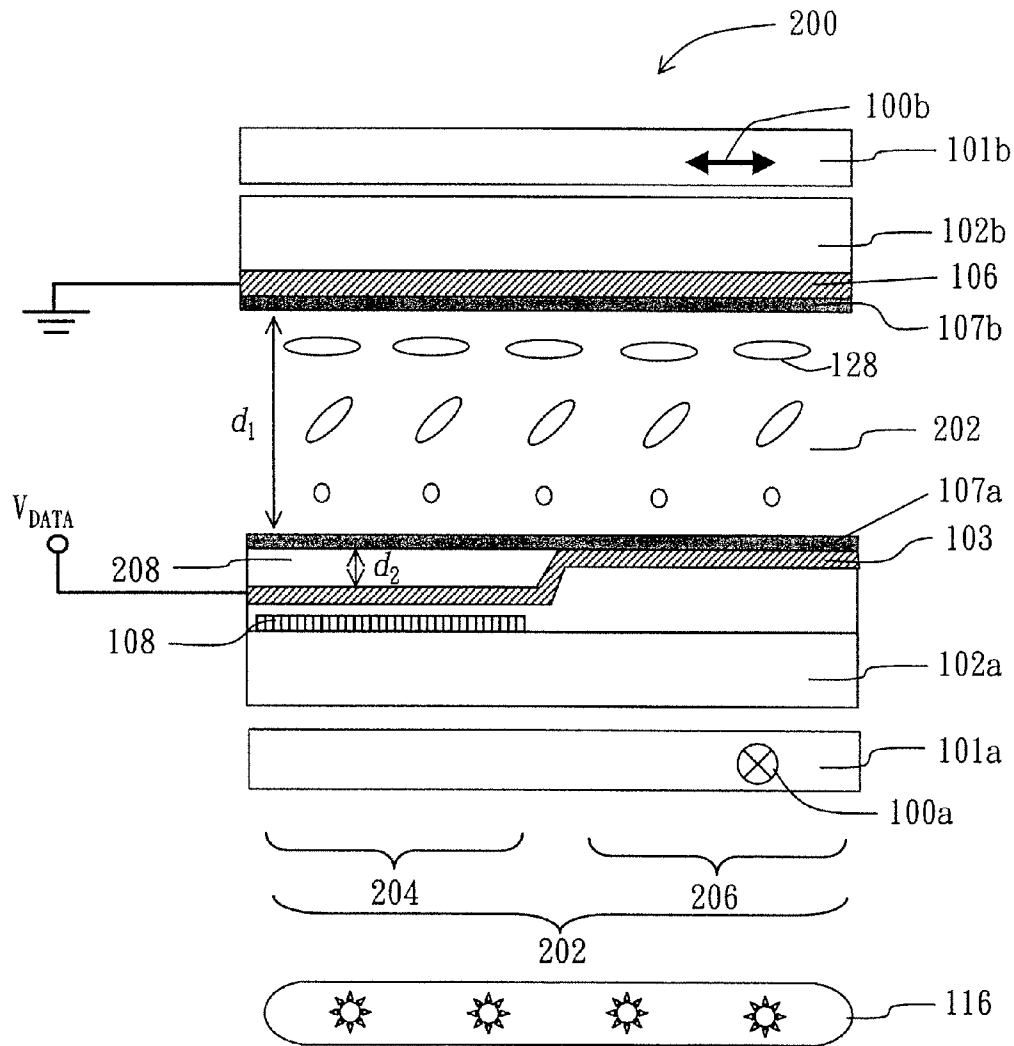

FIG. 10

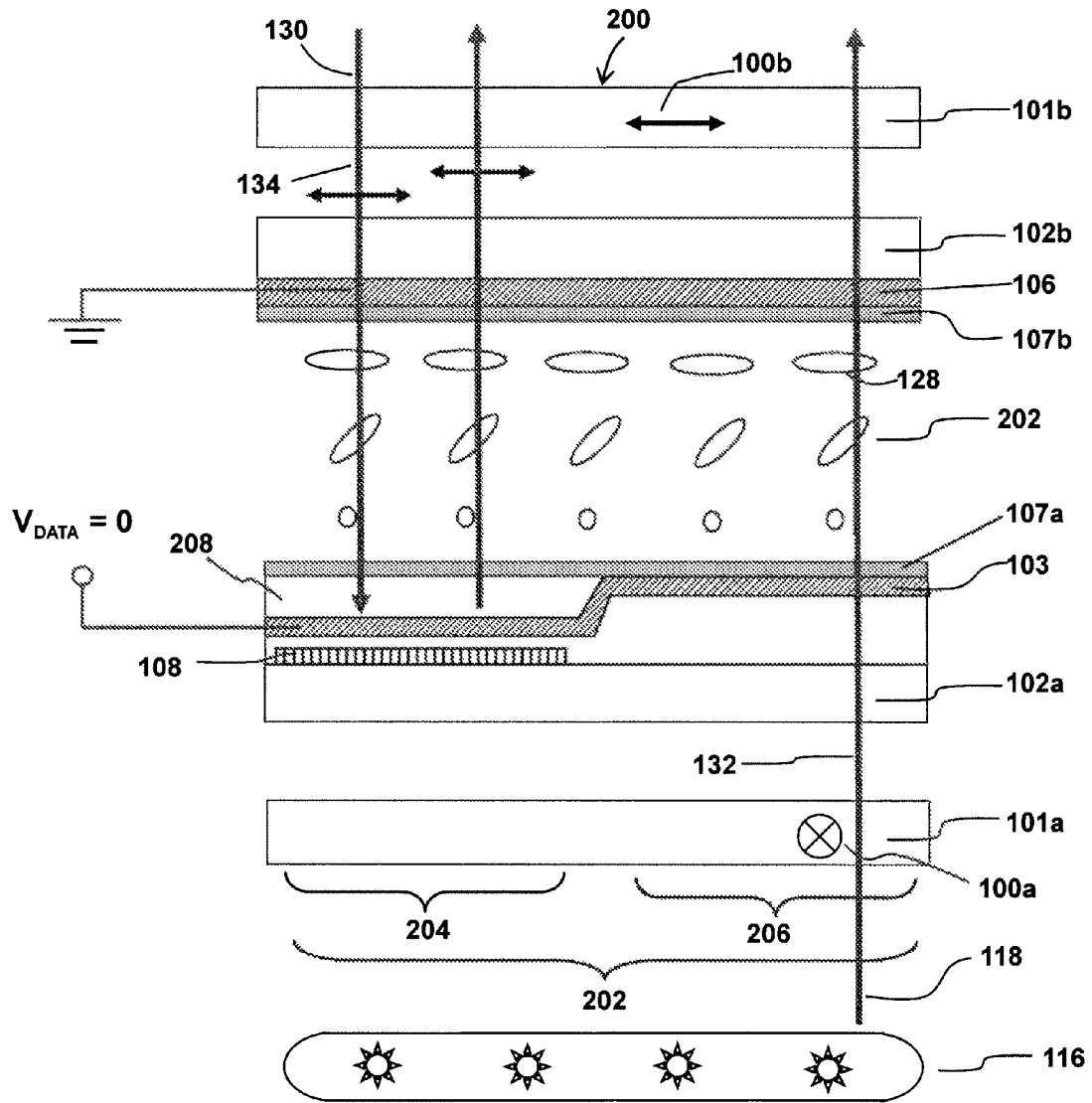

FIG. 11A

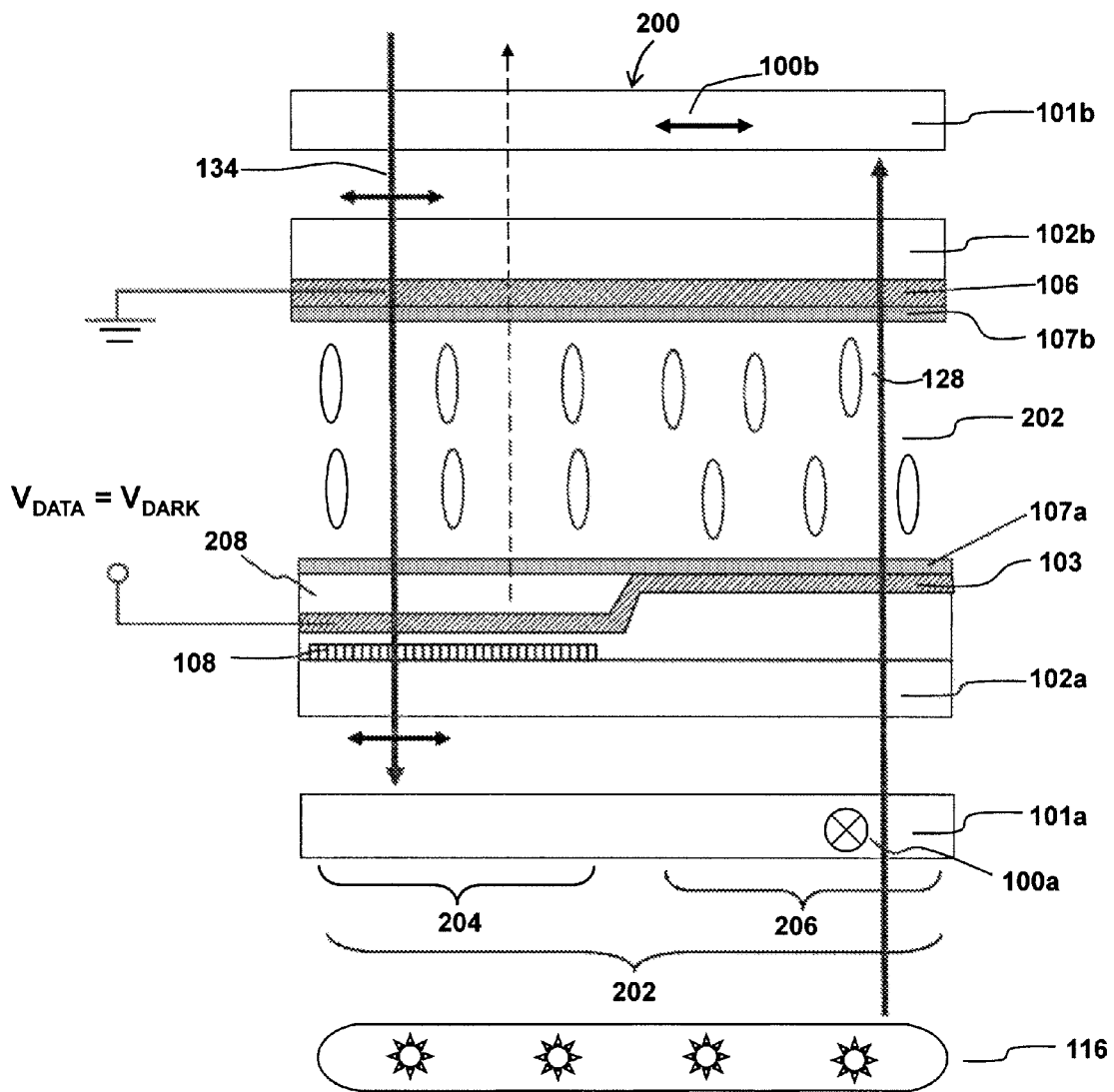

FIG. 11B

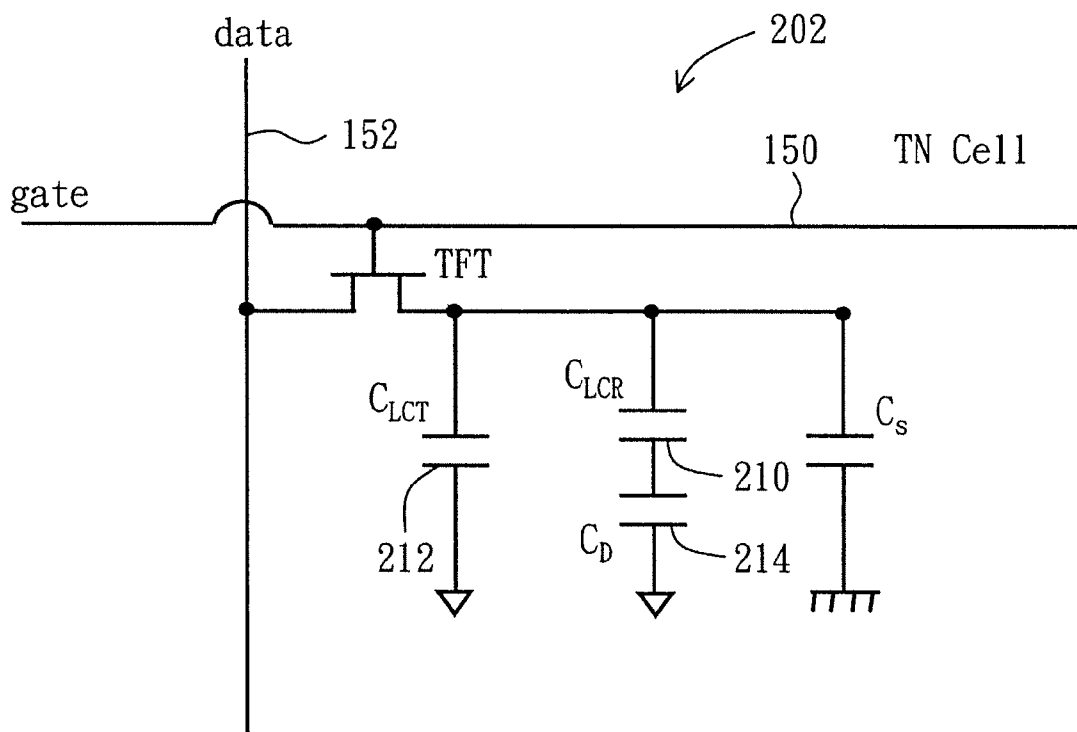

FIG. 12

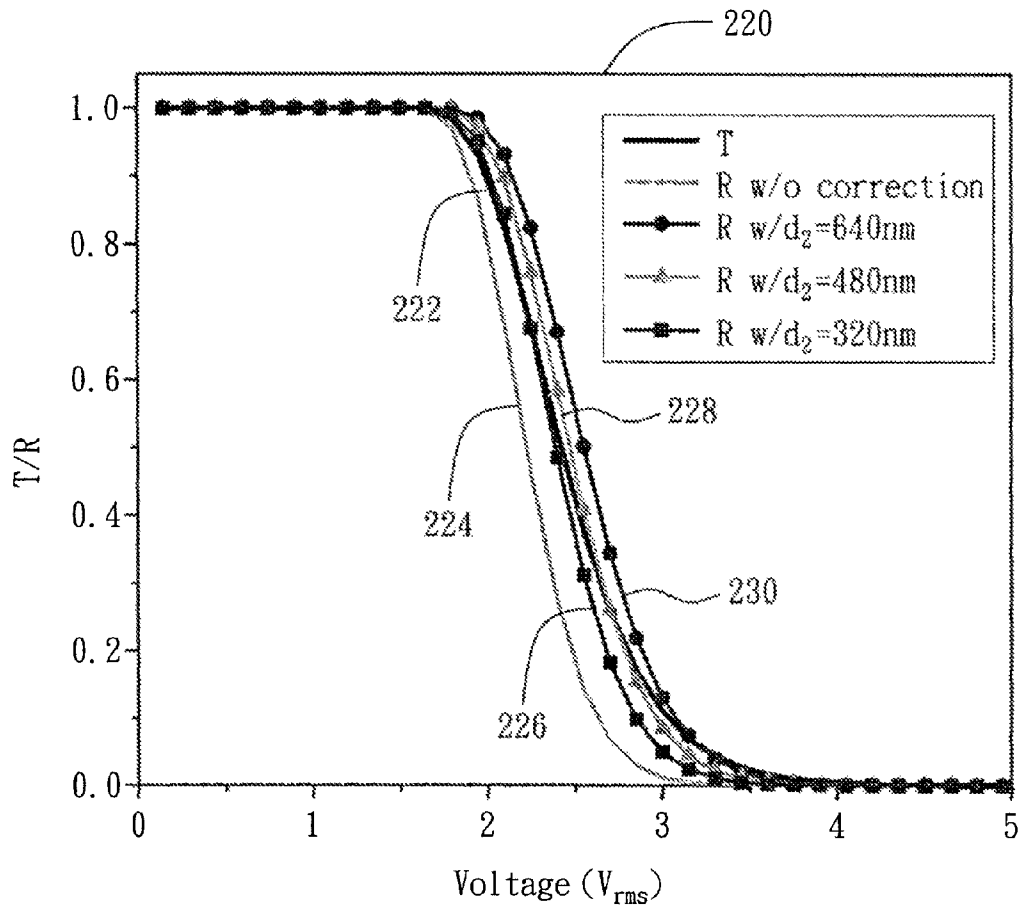

FIG. 13

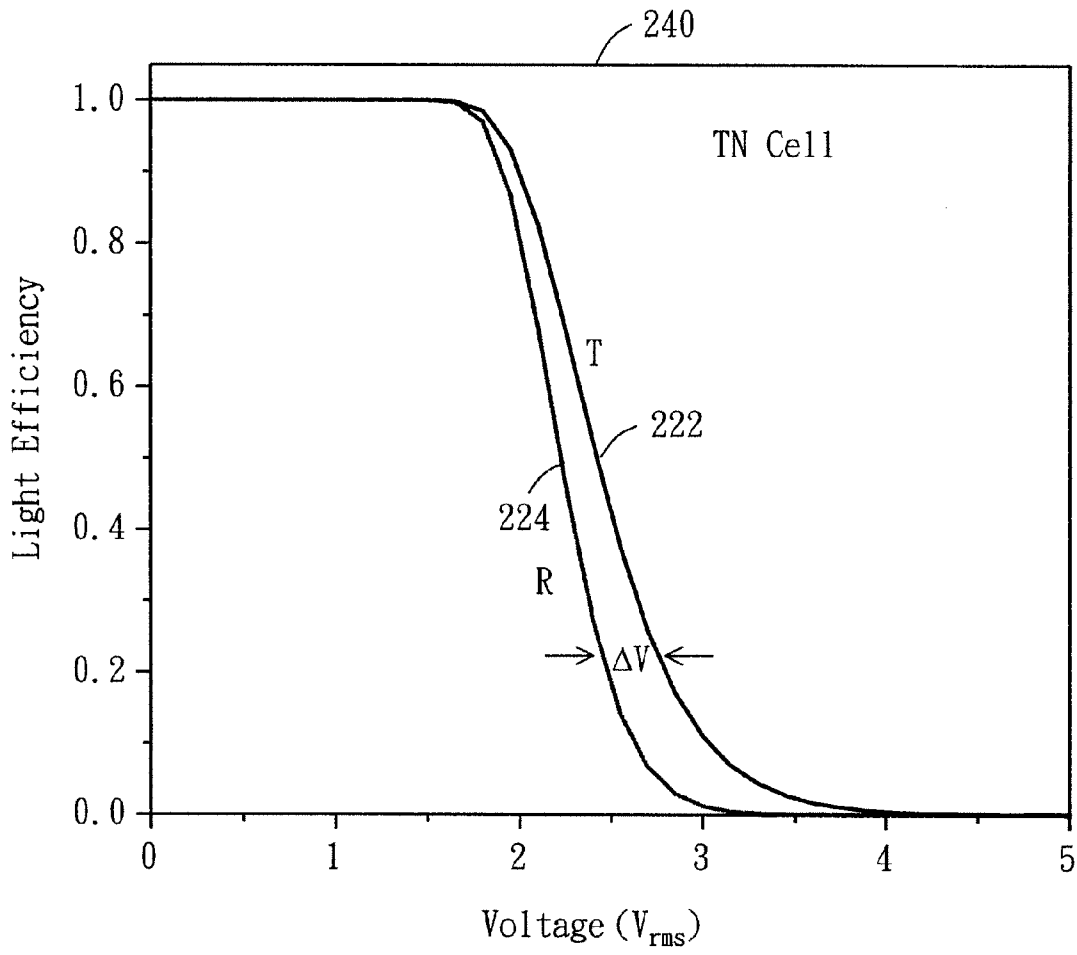

FIG. 14

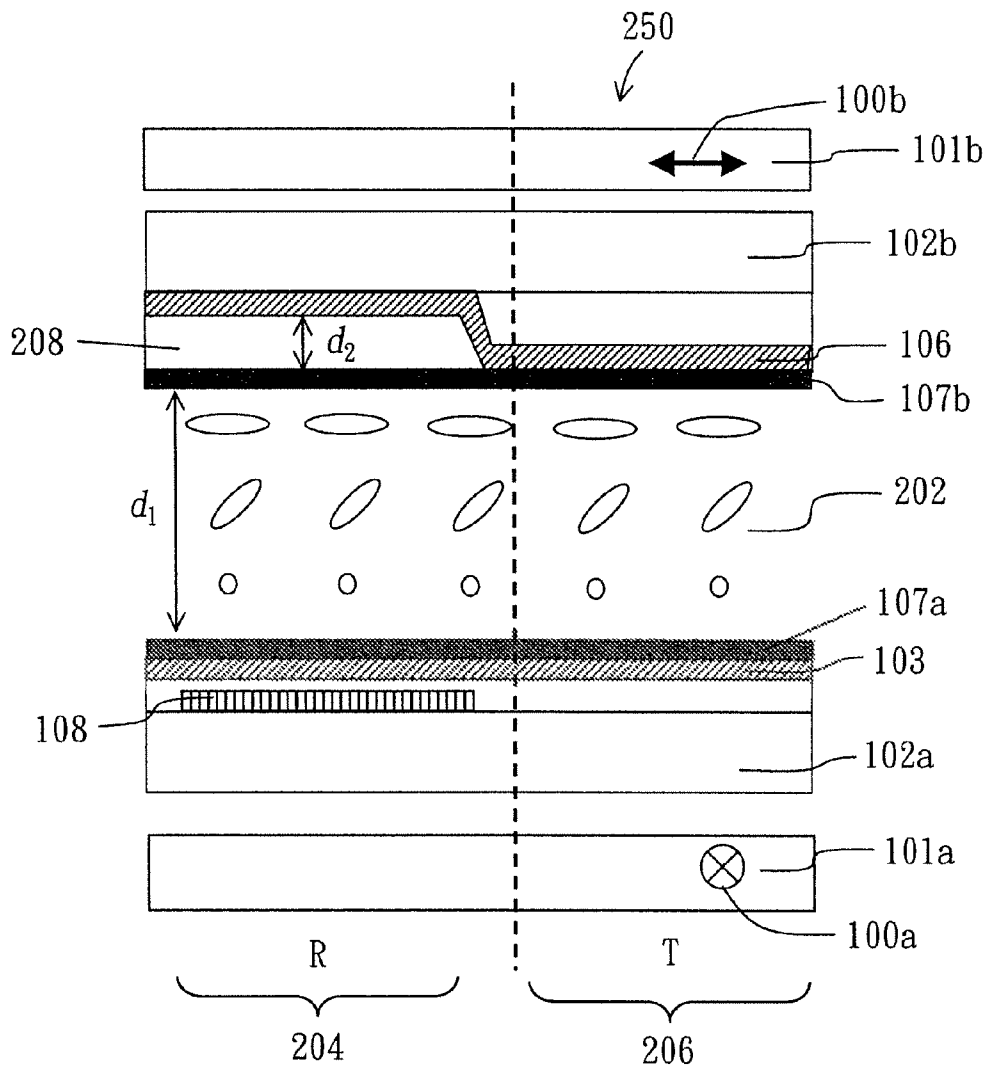

FIG. 15

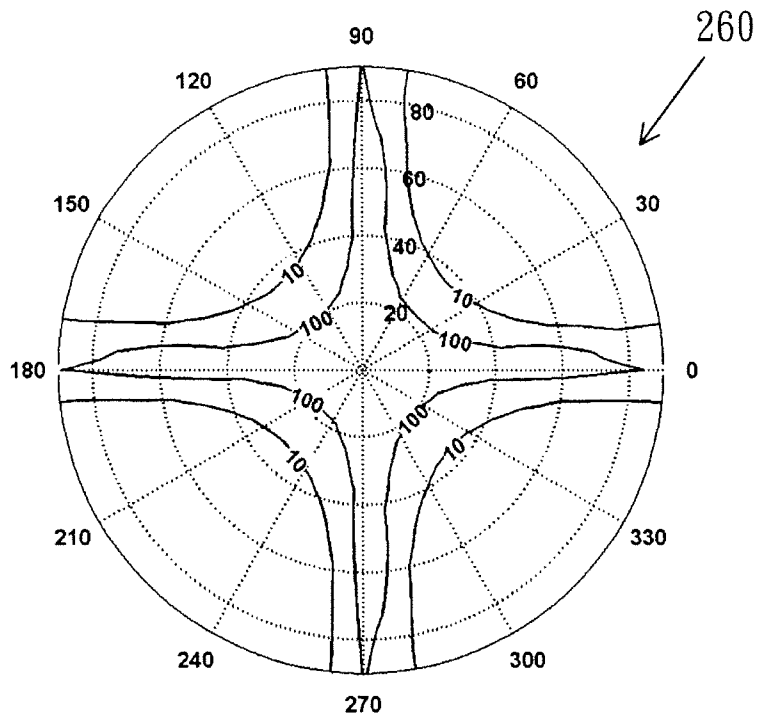

FIG. 16A

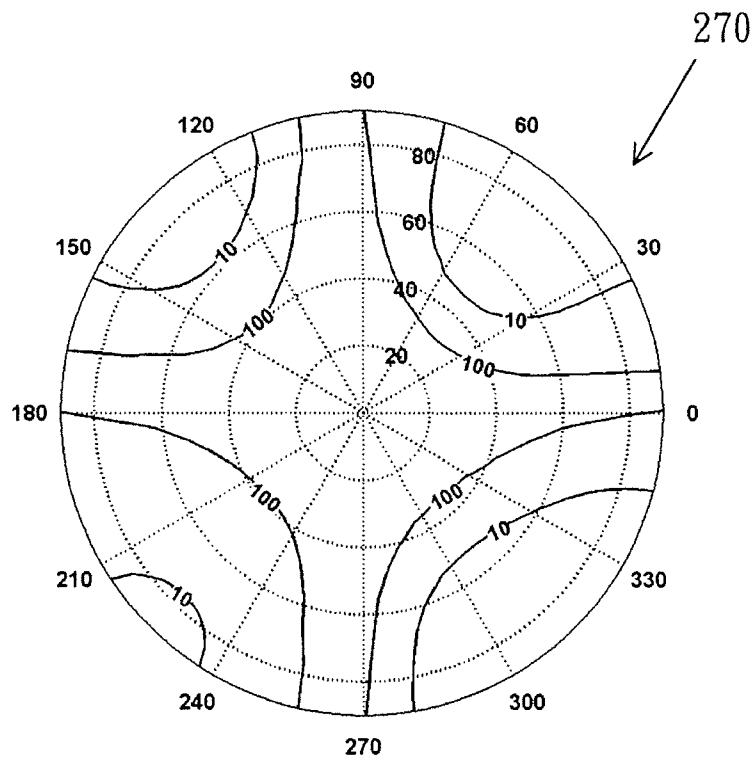

FIG. 16B

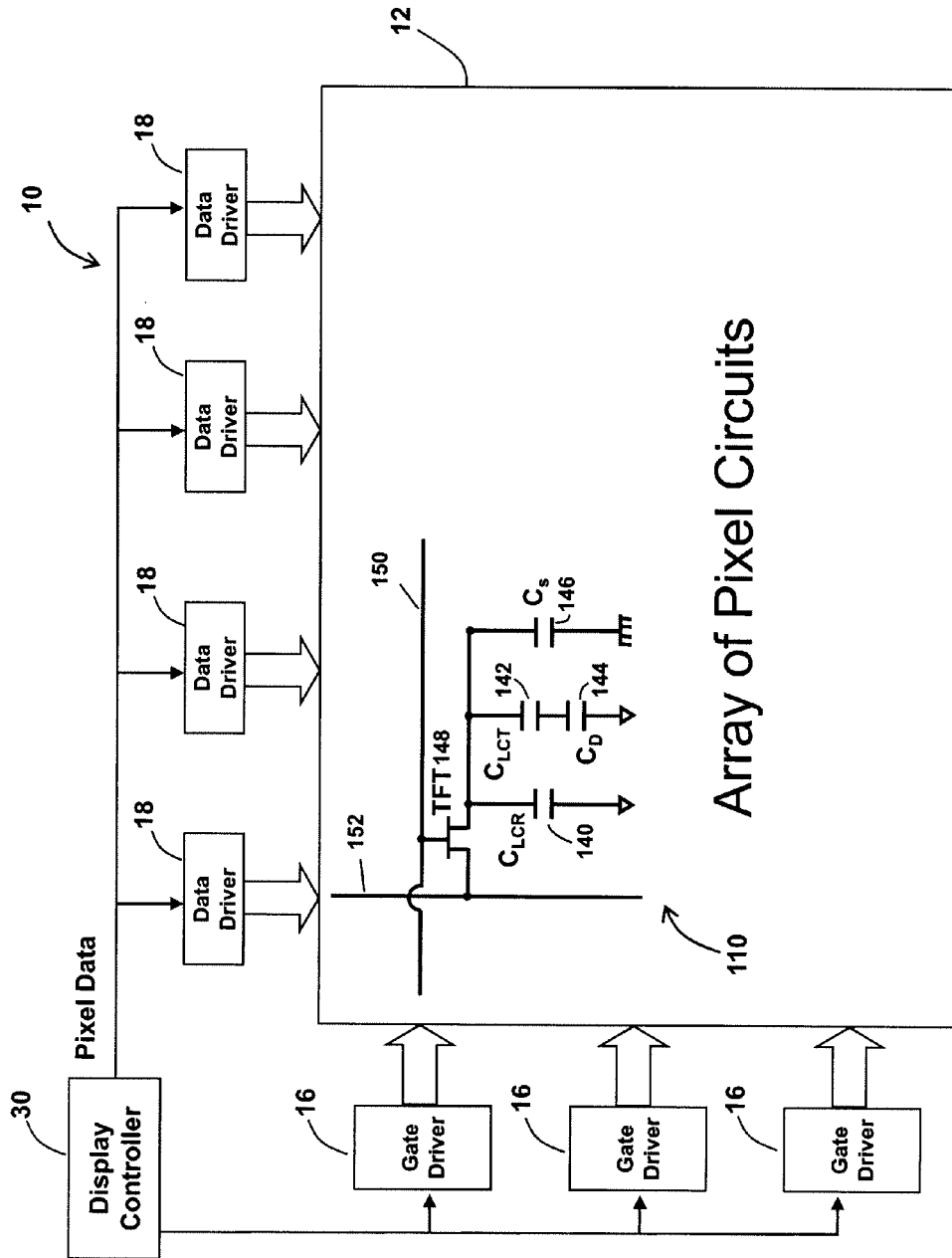

FIG. 17

1

**TRANSFLECTIVE LIQUID CRYSTAL
DISPLAY COMPRISING A DIELECTRIC
LAYER BETWEEN THE FIRST AND SECOND
ELECTRODES IN THE TRANSMISSIVE
REGION**

This application is a divisional of and claims the benefit of priority from U.S. application Ser. No. 11/678,691, filed Feb. 26, 2007 now abandoned, incorporated here by reference in its entirety.

BACKGROUND OF THE INVENTION

The description relates to transfective liquid crystal displays.

Liquid crystal displays (LCD) include transmissive type, reflective type, and transfective type displays. A transmissive type LCD includes a backlight module to generate light that is modulated by liquid crystal cells to generate images. The transmissive type LCD can have a high contrast ratio and good color saturation. A reflective type LCD includes a reflector to reflect ambient light that is modulated by liquid crystal cells to generate images. The reflective type LCD does not require a backlight module, and is useful in environments with strong ambient light. A transfective type LCD can operate in a transmissive mode and/or a reflective mode. In one example, each pixel of the transfective LCD is divided into a transmissive part (T sub-pixel) and a reflective part (R sub-pixel). When operating in the transmissive mode, a backlight module generates light that is modulated by the T sub-pixels. When operating in the reflective mode, reflected ambient light is modulated by the R sub-pixels.

SUMMARY

In one general aspect, a transfective liquid crystal display achieves good gray scale gamma curve match between transmissive and reflective modes by using an internal wire grid polarizer and a voltage shield capacitor in one of the transmissive or reflective sub-pixels depending on the liquid crystal mode. In some examples, the display does not use broadband circular polarizers, and can have wide viewing angles and high contrast ratios (e.g., a contrast ratio greater than 100:1 at 40 degree viewing angle for most directions).

In another general aspect, a display includes a plurality of pixel circuits, each pixel circuit including a first electrode, a second electrode, a reflective region, and a transmissive region. The reflective region reflects ambient light and includes a first portion of a liquid crystal layer between the first and second electrodes, and a polarization dependent reflector that transmits light having a first polarization and reflects light having a second polarization. The transmissive region transmits backlight and includes a second portion of the liquid crystal layer between the first and second electrodes. A dielectric layer is between the first and second electrodes in one of the reflective region and the transmissive region, the dielectric layer configured such that when a pixel voltage is applied to the first and second electrodes, the percentage of the pixel voltage applied across the first portion of the liquid crystal layer is different from the percentage of the pixel voltage applied across the second portion of the liquid crystal layer. The display includes a backlight module to generate the backlight.

Implementations of the display may include one or more of the following features. The polarization dependent reflector includes a wire grid polarizer. In some examples, the dielectric layer is in the reflective region and configured such that

2

when the pixel voltage is applied to the first and second electrodes, the percentage of the pixel voltage applied across the first portion of the liquid crystal layer is lower than the percentage of the pixel voltage applied across the second portion of the liquid crystal layer. The liquid crystal layer is between two substrates, and the liquid crystal layer includes liquid crystal molecules that are substantially aligned along a direction parallel to the surfaces of the substrates when no voltage is applied to the first and second electrodes. In some examples, the dielectric layer is in the transmissive region and configured such that when the pixel voltage is applied to the first and second electrodes, the percentage of the pixel voltage applied across the first portion of the liquid crystal layer is higher than the percentage of the pixel voltage applied across the second portion of the liquid crystal layer. The liquid crystal layer is between two substrates, and the liquid crystal layer includes liquid crystal molecules that are substantially aligned along a direction normal to the substrates when no voltage is applied to the first and second electrodes.

The dielectric layer has a dielectric constant and a thickness that are selected to reduce a difference between a transmittance of the transmissive region and a reflectance of the reflective region for a given pixel voltage applied to the first and second electrodes. The dielectric layer functions as a capacitor that is connected in series with the liquid crystal layer between the first and second electrodes. The dielectric layer includes at least one of silicon oxide and silicon nitride. At least one of the first electrode and the second electrode includes at least one of indium tin oxide, indium zinc oxide, and gallium zinc oxide. The display includes a first linear polarizer and a second linear polarizer that both extend over the transmissive and reflective regions, the first and second linear polarizers being at different sides of the liquid crystal layer. The first linear polarizer is closer to a viewer than the second linear polarizer, and the polarization dependent reflector has a reflective axis that is perpendicular to a transmission axis of the first linear polarizer. The liquid crystal layer is between two substrates, and the liquid crystal layer includes liquid crystal molecules that are substantially aligned along a direction normal to the substrates when no voltage is applied to the first and second electrodes. In some examples, the liquid crystal layer includes a negative dielectric anisotropic liquid crystal material. In some examples, the liquid crystal layer includes a positive dielectric anisotropic liquid crystal material.

In another general aspect, a display includes a first substrate, a second substrate, and pixel circuits between the first and second substrates. Each pixel circuit has a transmissive portion and a reflective portion. Each pixel circuit includes a first electrode, a second electrode, a liquid crystal cell, a polarization dependent reflector located at the reflective portion, and a shield capacitor located at one of the reflective and transmissive portions and positioned in series with the liquid crystal cell.

Implementations of the display may include one or more of the following features. The shield capacitor is configured to cause a gray scale gamma curve of the transmissive region to more closely match a gray scale gamma curve of the reflective region, as compared to the pixel circuit without the shield capacitor. In some examples, the pixel circuits are in dark states when no pixel voltage is applied to the pixel circuits. In some examples, the pixel circuits are in bright states when no pixel voltage is applied to the pixel circuits.

In another general aspect, a transfective display includes a first linear polarizer having a first transmission axis, a second linear polarizer having a second transmission axis, the first linear polarizer located closer to a front side of the display

than the second linear polarizer, and pixel circuits. Each pixel circuit includes a liquid crystal layer between the first and second linear polarizers, the liquid crystal layer having a first portion and a second portion, the first portion corresponding to a reflective portion of the pixel circuit, the second portion corresponding to a transmissive portion of the pixel circuit. Each pixel circuit includes a storage capacitor to store an electric charge corresponding to a pixel voltage and a polarization dependent reflector that is associated with the first portion of the liquid crystal layer. The polarization dependent reflector reflects a first component of external light and transmits a second component of the external light, the first component having a first polarization substantially perpendicular to the first transmission axis and the second component having a second polarization substantially parallel to the first transmission axis. Each pixel circuit includes means for applying a first percentage of the pixel voltage to the first portion of the liquid crystal layer and a second percentage of the pixel voltage to the second portion of the liquid crystal layer, the first percentage being different from the second percentage.

Implementations of the transfective display may include one or more of the following features. The means for applying the first and second percentages of the pixel voltage is configured to cause the transmissive portion to have a transmittance-voltage characteristic that more closely matches a reflectance-voltage characteristic of the reflective portion, as compared to a pixel circuit that applies the same percentage of the pixel voltage to the first and second portions of the liquid crystal layer.

In another general aspect, a method includes reflecting external light having a first polarization after the external light passes a liquid crystal layer in a reflective region of a pixel of a display, the reflected light being directed toward a viewer of the display. The method includes transmitting external light having a second polarization after the external light passes the liquid crystal layer in the reflective region, the transmitted light being directed away from the viewer, and transmitting backlight through the liquid crystal layer in a transmissive region of the pixel, the transmitted light being directed toward the viewer. The method includes applying a first percentage of a pixel voltage to the liquid crystal layer in the reflective region, and applying a second percentage of the pixel voltage to the liquid crystal layer in the transmissive region, the second percentage being different from the first percentage.

Implementations of the method may include one or more of the following features. The first and second percentages are configured to cause the transmittance of the transmissive region to more closely match the reflectance of the reflective region for a given pixel voltage, as compared to applying a same percentage of the pixel voltage to the reflective and transmissive regions. In some examples, the method includes showing a dark state at the pixel when the pixel voltage is below a threshold. In some examples, the method includes showing a bright state at the pixel when the pixel voltage is below a threshold. In some examples, the method includes aligning liquid crystal molecules of the liquid crystal layer along directions substantially normal to surfaces of two substrates when no voltage is applied to the first and second electrodes, the liquid crystal layer being positioned between the two substrates. In some examples, the method includes aligning liquid crystal molecules of the liquid crystal layer along directions substantially parallel to surfaces of two substrates when no voltage is applied to the first and second electrodes, the liquid crystal layer being positioned between the two substrates.

In another general aspect, a method includes forming a polarization dependent reflector in a first region of first substrate, the first region corresponding to a reflective region of a pixel of a display, forming a first electrode on the first substrate, and forming a second electrode on a second substrate. The method includes forming a dielectric layer on a portion of the first electrode or a portion of the second electrode, the dielectric layer corresponding to either the reflective region of the pixel or a transmissive region of the pixel, and providing a liquid crystal layer between the first and second substrates, the dielectric layer being positioned in series with the liquid crystal layer between the first and second electrodes.

Implementations of the method may include one or more of the following features. In some examples, the method includes providing alignment layers on the first and second substrates to cause the liquid crystal molecules of the liquid crystal layer to substantially align along a direction normal to the surfaces of the substrates when no voltage is applied to the first and second electrodes. In some examples, the method includes providing alignment layers on the first and second substrates to cause the liquid crystal molecules of the liquid crystal layer to substantially align along a direction parallel to the surfaces of the substrates when no voltage is applied to the first and second electrodes. The method includes providing a first linear polarizer at a side of the first substrate facing away from the liquid crystal layer, and providing a second linear polarizer at a side of the second substrate facing away from the liquid crystal layer, the first linear polarizer having a transmission axis that is non-parallel to a transmission axis of the second linear polarizer.

DESCRIPTION OF DRAWINGS

FIG. 1 is a diagram of a transfective liquid crystal display. FIG. 2 is a diagram of a wire grid polarizer. FIGS. 3A and 3B are cross-sectional diagrams of a VA mode transfective liquid crystal display. FIG. 4 is a diagram of an equivalent circuit. FIG. 5 is a diagram of capacitances. FIGS. 6 and 7 are graphs of voltage-reflectance and voltage-transmittance characteristics. FIG. 8 is a cross-sectional diagram of a VA mode transfective liquid crystal display. FIG. 9 is a cross-sectional diagram of a VA mode transfective liquid crystal display. FIGS. 10, 11A, and 11B are cross-sectional diagrams of a TN mode transfective liquid crystal display. FIG. 12 is a diagram of an equivalent circuit. FIGS. 13 and 14 are graphs showing voltage-reflectance and voltage-transmittance characteristics. FIG. 15 is a cross-sectional diagram of a TN mode transfective liquid crystal display. FIGS. 16A and 16B are iso-contrast plots. FIG. 17 is a block diagram of a liquid crystal display.

DETAILED DESCRIPTION

FIG. 1 is a cross-sectional diagram of an example of a transfective liquid crystal display 100 that includes a vertically aligned liquid crystal layer 104 positioned between a lower glass substrate 102a and an upper glass substrate 102b. A lower linear polarizer 101a is attached to an outer side of the lower substrate 102a, and an upper linear polarizer 101b is attached to an outer side of the upper substrate 102b. The lower linear polarizer 101a has a transmission axis 100a that is perpendicular to the transmission axis 100b of the upper polarizer 101b. An upper transparent electrode 106 (which

functions as a common electrode) and an upper alignment layer **107b** are positioned on an inner side of the upper substrate **102b**. On an inner side of the lower substrate **102a** are a wire grid polarizer **108**, passivation layer **105**, a lower transparent electrode **103** (which functions as a pixel electrode), and a lower alignment layer **107a**. The lower and upper alignment layers **107a** and **107b** are used to align liquid crystal molecules **128** in the liquid crystal layer **104**. A backlight module **116** provides backlight when the display **100** is used in the transmissive mode.

In this description, the terms “upper” and “lower” refer to relative positions of the components of the display **100**. An upper layer is closer to the viewer than a lower layer.

The transparent electrodes **103** and **106** can be made of, e.g., indium tin oxide (ITO), indium zinc oxide (IZO), and gallium zinc oxide (GZO). The alignment layers **107a** and **107b** can be made of, e.g., polyimide materials.

The display **100** includes an array of pixels **110**, one of which is shown in FIG. 1. The pixel **110** includes a reflective (R) sub-pixel **112** and a transmissive (T) sub-pixel **114**. The wire grid polarizer **108** is a reflective type polarizer or a polarization-dependent reflector, and is located in the R sub-pixel **112**. The wire grid polarizer **108** includes metal strips **120** (see FIG. 2) formed on the lower substrate **102a**. The metal strips **120** extend along a direction **138** (referred to as the lengthwise direction of the metal strips **120**). In this example, the lengthwise direction **138** of the metal strips **120** is perpendicular to the transmission axis **100b** of the upper linear polarizer **101b**.

The wire grid polarizer **108** has a transmission axis that is perpendicular to the lengthwise direction **138** of the metal strips **120** and a reflection axis that is parallel to the lengthwise direction **138** of the metal strips **120**. When an unpolarized incident light **122** (FIG. 2) impinges on the surface of the wire grid polarizer **108**, a first component of the light **124** (FIG. 2) having a polarization parallel to the lengthwise direction of the metal strips **120** is reflected, and a second component of the light **126** (FIG. 2) having a polarization perpendicular to the metal strips passes through the wire grid polarizer **108**.

Each pixel **110** includes a storage capacitor C_S (see FIGS. 4 and 17) for storing a pixel voltage, and a thin film transistor (FIGS. 4 and 17) for driving the storage capacitor C_S . Within each pixel **110**, the thin film transistor, the storage capacitor, the upper electrode **106**, the liquid crystal layer **104**, the lower electrode **103**, the wire grid polarizer **108**, and the dielectric layer **105** are collectively referred to as a pixel circuit **14** (FIGS. 4 and 17). The pixel circuits **14** can be individually addressed by using gate lines **150** and data lines **152** (FIGS. 4 and 17). The linear polarizers **101a** and **101b**, the glass substrates **102a** and **102b**, the alignment layers **107a** and **107b**, and the liquid crystal layer **104** extend over several pixels **110**.

In the T sub-pixel **114**, the passivation layer **105** having a thickness d_2 is positioned between the lower transparent ITO electrode **103** and the lower alignment layer **107a**. In the R sub-pixel **112**, the lower electrode **103** is directly adjacent to the lower alignment layer **107a**. When a pixel voltage V_{DATA} is applied to the lower and upper electrodes **103** and **106** (i.e., generating a voltage difference equal to V_{DATA} between the lower and upper electrodes), the percentages of the pixel voltage V_{DATA} applied to the liquid crystal layer **104** in the R and T sub-pixels **112** and **114** are different.

In the R sub-pixel **112**, substantially all of the pixel voltage V_{DATA} is applied to the liquid crystal layer **104**. In the T sub-pixel **114**, the pixel voltage V_{DATA} is applied to both the liquid crystal layer **104** and the passivation layer **105**, so the percentage of the pixel voltage V_{DATA} applied to the liquid

crystal layer **104** in the T sub-pixel **114** is less than that in the R sub-pixel **112**. The passivation layer **105** functions as a shield capacitor that reduces the amount of pixel voltage applied to the liquid crystal layer **104** in the T sub-pixel **114**.

Referring to FIG. 2, the wire grid polarizer **108** includes metal strips **120** aligned in a direction parallel to the transmission axis **100a** of the lower polarizer **101a**. In some examples, each metal strip **120** has a thickness t and a width w , and the spacing between the metal strips **120** is p . When unpolarized incident light **122** is directed towards the surface of the wire grid polarizer **108**, a first component **124** of the light **122** having a polarization parallel to the lengthwise direction of the metal strips **120** is reflected, and a second component **126** of the light **122** having a polarization perpendicular to the lengthwise direction of the metal strips **120** passes through the wire grid polarizer **108**.

The following describes operation of the pixel **110** during the dark and bright states. If the display **100** uses gray scale levels ranging from 0 to 255, the dark state corresponds to the gray scale level 0, and the bright state corresponds to the gray scale level 255.

Referring to FIG. 3A, when no voltage is applied to the lower and upper electrodes **103** and **106**, the liquid crystal molecules **128** are aligned in the vertical direction. In the T sub-pixel **114**, backlight **118** from the backlight module **116** passes the lower linear polarizer **101a** and becomes linearly polarized light **132** having a polarization direction parallel to the transmission axis **100a** of the lower linear polarizer **101a**. The linearly polarized light **132** passes the liquid crystal layer **104** without changing its polarization, and is blocked by the upper polarizer **101b**.

In the R sub-pixel **112**, incident ambient light **130** first passes the upper polarizer **101b** and becomes linearly polarized light **134** having a polarization parallel to the transmission axis **100b** of the upper polarizer **101b**. The linearly polarized light **134** maintains its polarization after passing the liquid crystal layer **104**. Because the linearly polarized light **134** has a polarization perpendicular to the metal strips **120** of the wire grid polarizer **108**, the linearly polarized light **134** passes the wire grid polarizer **108** and is absorbed by the lower polarizer **101a**.

Referring to FIG. 3B, when a pixel voltage $V_{DATA}=V_{BRIGHT}$ that corresponds to a bright state is applied to the electrodes **103** and **106**, the liquid crystal molecules **128** are rotated by an electric field. The pixel voltage V_{BRIGHT} for the bright state is selected such that the liquid crystal layer **104** becomes similar to a half-wave plate.

In this description, when a layer or film is said to behave similar to a half-wave plate, it means that the layer or film behave similar to a half-wave plate for a specified wavelength, e.g., 589 nm. Similarly, when a layer or film is said to behave similar to a quarter-wave plate, it means that the layer or film behave similar to a quarter-wave plate for the specified wavelength.

In the R sub-pixel **112**, the polarization of the linearly polarized light **134** is rotated by 90 degrees as the light **134** passes the liquid crystal layer **104**, and becomes parallel to the lengthwise direction of the metal strips **120** of the wire grid polarizer **108**. The light is reflected by the wire grid polarizer **108** back to the liquid crystal layer **104** as reflected light **136**. After the reflected light **136** passes the liquid crystal layer **104**, its polarization is rotated again by 90 degrees to become parallel to the transmission axis **100b** of the upper polarizer **101b**. The reflected light **136** passes the upper polarizer **101b** and is seen by the user as a bright R sub-pixel **112**.

In the T sub-pixel **114**, as the linearly polarized light **132** passes the liquid crystal layer **104**, the polarization of the light

132 is rotated by 90 degrees so that the polarization is parallel to the transmission axis **100b** of the upper polarizer **101b**. The light passes the upper polarizer **101b** and is seen by the user as a bright T sub-pixel **114**.

Although the passivation layer **105** causes the percentage of the pixel voltage applied to the R and T sub-pixels **112** and **114** to be different, the pixel voltage V_{BRIGHT} is selected to be sufficiently high so that the liquid crystal molecules **128** in both the R and T sub-pixels **112** and **114** are substantially parallel to the surface of the substrates **102a** and **102b**. The cell gap **d1** of the liquid crystal layer **104** is selected such that when the liquid crystal molecules **128** are substantially aligned parallel to the substrates **102a** and **102b**, the liquid crystal layer **104** behaves similar to a half wave plate.

In designing the display **100**, the cell gap **d1** of the liquid crystal layer **104** and the liquid crystal material are selected such that $\Delta n \cdot d1 = \lambda/2$ so that the liquid crystal layer **104** behaves similar to a half-wave plate in the bright state. The parameter Δn equals $n_e - n_o$, where n_e and n_o are the extraordinary and ordinary refractive indices, respectively, of the liquid crystal material. In some examples, $\Delta n \cdot d1$ is selected to be slightly larger than $\lambda/2$ because there may be a small amount of phase loss at boundaries of the liquid crystal layer, and a higher $\Delta n \cdot d1$ allows the bright state to be achieved at a lower pixel data voltage. Selection of the liquid crystal material may take into consideration factors such as a large Δn value to reduce the required cell gap, a high dielectric anisotropy ($\Delta\epsilon$) to reduce the on-state driving voltage, and a low viscosity to reduce the response time.

When the pixel voltage corresponds to a gray scale voltage between the dark state and the bright state (e.g., a gray scale level between 0 and 255), the percentages of the pixel voltage V_{DATA} applied to the R sub-pixel **112** and the T sub-pixel **114** are different, as described below.

FIG. 4 shows a diagram of an equivalent circuit of the pixel **110** in FIG. 1. When the voltage on a gate line **150** is pulled high, the thin film transistor **148** of the pixel **100** is turned on, allowing the pixel voltage V_{DATA} on a data line **152** to charge a storage capacitor C_s (**146**) to the pixel voltage V_{DATA} . In this example, the TFT **148** is an N-type transistor. The portion of the liquid crystal layer **104** in the R sub-pixel **112** has an effective capacitance that is represented by a capacitor C_{LCR} (**140**). The portion of the liquid crystal layer **104** in the T sub-pixel **114** has an effective capacitance that is represented by a capacitor C_{LCT} (**142**). The passivation layer **105** is made of a dielectric material and has an effective capacitance represented by a capacitor C_D (**144**). The pixel voltage V_{DATA} is substantially fully applied to the liquid crystal layer **104** in the R sub-pixel **112**. By comparison, because C_D is connected in series with C_{LCT} , only a portion of the pixel voltage V_{DATA} is applied to the portion of the liquid crystal layer **104** in the T sub-pixel **114**.

Referring to FIG. 5, the capacitances C_{LCT} and C_D of the liquid crystal layer **104** and the passivation layer **105**, respectively, in the T sub-pixel are approximately equal to

$$C_{LCT} = \frac{\epsilon_{LC}}{d_1} \text{ and } C_D = \frac{\epsilon_D}{d_2},$$

respectively. If the voltage applied to the liquid crystal layer **104** in the R sub-pixel **112** and T sub-pixel **114** are denoted V_R and V_T , respectively, then

$$V_T = \frac{C_D}{C_D + C_{LCT}} V_R. \quad (\text{Equ. 1})$$

FIG. 6 is a graph **160** showing a curve **162** that represents the voltage-reflectance characteristics of the R sub-pixel **112**. Also shown are curves **164**, **166**, **168**, and **170** representing the voltage-transmittance characteristics of the T sub-pixel **114** when the passivation layer **105** has a thickness of 0, 350 nm, 500 nm, and 700 nm, respectively. The horizontal axis represents the voltage applied to the electrodes **103** and **106**, which is equal to the voltage V_R applied to the R sub-pixel **112**. The data points for the graph **160** were obtained using simulation. When the thickness **d2** of the passivation layer **105** is equal to 350 nm, the curve **162** more closely matches the curve **166** (as compared to the curve **164** versus curve **166**), indicating that the voltage-reflectance characteristic of the R sub-pixel **112** more closely matches the voltage-transmittance characteristic of the T sub-pixel **114**. The R sub-pixel **112** and the T sub-pixel **114** will show similar gray scale (or color) for a given pixel voltage V_{DATA} .

In the simulations used to obtain the data for the graph **160**, the liquid crystal material used was MLC-6608, available from Merck, Japan. The liquid crystal material has a parallel dielectric constant $\epsilon_{//} = 3.6$, perpendicular dielectric constant $\epsilon_{\perp} = 7.8$, and elastic constants $K_{11} = 16.7$ pN, $K_{22} = 7.0$ pN, and $K_{33} = 18.1$ pN. The liquid crystal material has an extraordinary refractive index $n_e = 1.5578$ and an ordinary refractive index $n_o = 1.4748$ at $\lambda = 589$ nm. The parameter $d1 \cdot \Delta n$ of the liquid crystal layer **104** is set at $0.36 \mu\text{m}$. The passivation layer **105** can be made of dielectric materials (e.g., SiO_2 , which has a dielectric constant of 3.9) that are compatible with the thin film transistor fabrication process.

The thickness of the passivation layer **105** can be estimated using a voltage shifting method. FIG. 7 is a graph **180** that shows the curves **162** and **164** of FIG. 6. The curves **162** and **164** represent the voltage reflectance characteristics of the R sub-pixel **112** and the voltage-transmittance characteristics of the T sub-pixel **114**, respectively, when the passivation layer **105** has a thickness $d2 = 0$. If the curve **164** is shifted towards the right of the figure, the curves **162** and **164** will more closely match each other. This means that for a given gray scale, the voltage level applied to the T sub-pixel **114** should be lower by a certain amount ΔV than the voltage level applied to the R sub-pixel **112**.

The differences in the V-R curve **162** and V-T curve **164** in FIG. 7 may be caused by the loss of light in the R sub-pixel **112** when the pixel voltage V_{DATA} corresponds to a gray scale between the dark and bright states. Referring to FIG. 8, when the pixel voltage V_{DATA} is at a level such that the phase retardation from the liquid crystal layer **104** is less than that from a half-wave plate, the linearly polarized light **134** will become elliptically polarized when the light **134** reaches the surface of the wire grid polarizer **108**. A portion of the light **134** (the component of the light perpendicular to the metal stripes **120**) passes the wire grid polarizer **108** and is absorbed by the lower polarizer **101a**. Thus, the amount of light **136** reflected by the wire grid polarizer **108** is less than the back-light **132** that passed the linear polarizer **101a**. This accounts for the lower luminance in the R sub-pixel **112** compared to the T sub-pixel **114** for a given pixel voltage V_{DATA} .

The amount of capacitance C_D that is needed to achieve an amount of voltage shift so that the V-R curve **162** more closely matches the V-T curve **164** can be determined as follows. Referring back to FIG. 7, assume for a given light efficiency, the voltage applied to the liquid crystal layer **104** in the R

sub-pixel is V_R , and the voltage applied to the liquid crystal layer **104** in the T sub-pixel is V_T and $V_R = V_T + \Delta V$.

Replacing V_R with $V_T + \Delta V$ in Equ. 1, the following can be obtained:

$$V_T = \frac{C_D}{C_D + C_{LC}} (V_T + \Delta V). \quad (\text{Equ. 2})$$

In Equ. 2,

$$C_D = \frac{\epsilon_D}{d_2} \text{ and } C_{LC} = \frac{\epsilon_{LC}}{d_1}.$$

The dielectric constants ϵ_D and ϵ_{LC} are determined by the material used for the passivation layer **105** and the liquid crystal layer **104**. The dielectric constant ϵ_{LC} is a value between ϵ_{\parallel} and ϵ_{\perp} based on the liquid crystal director distribution at different gray levels. For example, when the liquid crystal molecules are mostly aligned perpendicular to the substrates, ϵ_{LC} is close to ϵ_{\parallel} , and when the molecules are mostly aligned parallel to the substrates, then ϵ_{LC} is close to ϵ_{\perp} . The thickness d_1 of the liquid crystal material is selected such that the liquid crystal layer **104** behaves like a half wave plate in the bright state. In this example, $n_e = 1.5578$ and $n_o = 1.4748$ at $\lambda = 589$ nm, and $d_1 \cdot \Delta n$ of the liquid crystal layer **104** is set at $0.36 \mu\text{m}$, so $d_1 = 4.34 \mu\text{m}$.

V_T and ΔV can be selected from any point on the curve **164**. For example, the threshold voltage (at point P on curve **164**) of the T sub-pixel is approximately 2.1 V, and the threshold voltage (at point Q on curve **162**) of the R sub-pixel is approximately 2.4 V, so ΔV is approximately 0.3 V. When the values for $V_T = 2.1$ V, $\Delta V = 0.3$ V, $d_1 = 4.34 \mu\text{m}$, $\epsilon_D = 3.9$, and $\epsilon_{LC} \sim 3.6$ are used in Equ. 2, it can be determined that d_2 is approximately 670 nm, which approximately matches the value $d_2 = 700$ nm determined by simulations shown in FIG. 6 when the matching point (the point where the V-R curve matches the V-T curve) is set at $V_T = 2.1$ V or $V_R = 2.4$ V (point P or Q, respectively, in FIG. 7). In FIG. 6, the V-R curve **162** matches the V-T curve **170** (representing $d_2 = 700$ nm) at $V_R = 2.4$ V, corresponding to a transmittance and a reflectance about zero. In order for the V-T and V-R curves to match each other at an intermediate gray level, the thickness of the d_2 can be adjusted to a smaller value, such as 350 nm. For example, in FIG. 6, the V-R curve **162** matches the V-T curve **166** (representing $d_2 = 350$ nm) at $V_R = 3.5$ V, corresponding to a transmittance and reflectance of about 60%.

FIG. 9 is a cross-sectional diagram of an example of a transmissive liquid crystal display **190** that is similar to the transmissive liquid crystal display **100** of FIG. 1. The difference between displays **100** and **190** is that in the T sub-pixel **114** of the display **190**, the passivation layer **105** is positioned between the upper electrode **106** and the upper alignment layer **107b**. The lower electrode **103** is directly adjacent to the lower alignment layer **107a**. In the display **190**, similar to the display **100**, when a pixel voltage V_{DATA} is applied to the electrodes **103** and **106**, the percentage of the pixel voltage V_{DATA} applied to the liquid crystal layer **104** in the R sub-pixel **112** is higher than that in the T sub-pixel **114**.

FIG. 10 is a cross-sectional diagram of an example of a transmissive liquid crystal display **200** that includes a twisted nematic type liquid crystal layer **202** positioned between a lower glass substrate **102a** and an upper glass substrate **102b**. FIG. 10 shows a pixel **202** that includes a R sub-pixel **204** and a T sub-pixel **206**. The display **200** has a lower linear polarizer

101a, an upper linear polarizer **101b**, a wire grid polarizer **108**, a lower alignment layer **107a**, an upper alignment layer **107b**, and an upper transparent electrode **106**, similar to those in the display **100** of FIG. 1.

In the display **200**, in the R sub-pixel **204**, a passivation layer **208** is positioned between the lower electrode **103** and the lower alignment layer **204**. In the T sub-pixel **206**, the lower electrode **103** is directly adjacent to the lower alignment layer **107a**. When a pixel voltage V_{DATA} is applied to the electrodes **103** and **106**, all of the pixel voltage V_{DATA} is applied to the liquid crystal layer **202** in the T sub-pixel **206**, and a lower percentage of the pixel voltage V_{DATA} is applied to the liquid crystal layer **202** in the R sub-pixel **204**.

When no voltage is applied to the electrodes **103** and **106**, the liquid crystal molecules **128** of the liquid crystal layer **202** are substantially parallel to the surface of the substrates **101a** and **101b**. The directors of the liquid crystal molecules **128** are oriented at different directions depending on the position of the molecules **128**. The liquid crystal molecules **128** form a twisted structure in which the molecules **128** rotate 90 degrees from a position adjacent to the lower alignment layer **107a** to a position adjacent to the upper alignment layer **107b**. The liquid crystal molecules **128** adjacent to the lower alignment layer **107a** are aligned substantially parallel to the transmission axis **100a** of the lower linear polarizer **101a**, and liquid crystal molecules **128** adjacent to the upper alignment layer **107b** are aligned substantially parallel to the transmission axis **100b** of the upper linear polarizer **101b**.

When a pixel voltage $V_{DATA} = V_{DARK}$ corresponding to a dark state is applied to the electrodes **103** and **106**, the liquid crystal molecules **128** of the liquid crystal layer **202** are tilted by the electric field generated by the pixel voltage V_{DATA} . The level of the pixel voltage for the dark state is selected such that the liquid crystal molecules **128** become substantially aligned along a direction normal to the surfaces of the substrates **102a** and **102b**.

The following describes the operation of the display **200**.

Referring to FIG. 11A, when no voltage is applied to the lower and upper electrodes **103** and **106**, the liquid crystal molecules **128** form a twisted structure as described above. In the T sub-pixel **206**, backlight **118** from the backlight module **116** passes the lower linear polarizer **101a** and becomes linearly polarized light **132** having a polarization direction parallel to the transmission axis **100a** of the lower linear polarizer **101a**. As the linearly polarized light **132** passes the liquid crystal layer **202**, the polarization of the light **132** is rotated 90 degrees and becomes parallel to the transmission axis **100b**. The light **132** passes the upper polarizer **101b** and is seen by the viewer as a bright T sub-pixel **206**.

In the R sub-pixel **204**, incident ambient light **130** first passes the upper polarizer **101b** and becomes linearly polarized light **134** having a polarization direction parallel to the transmission axis **100b** of the upper polarizer **101b**. The polarization of the linearly polarized light **134** is rotated 90 degrees as the light **134** passes the liquid crystal layer **202** and becomes parallel to the lengthwise direction of the metal strips **120** on the wire grid polarizer **108**. The linearly polarized light **134** is reflected by the wire grid polarizer **108**. The reflected light initially has a polarization parallel to the lengthwise direction of the metal strips **120**. As the reflected light passes the liquid crystal layer **202**, the polarization of the reflected light is rotated 90 degrees and becomes parallel to the transmission axis of the upper polarizer **100b**. The reflected light passes the upper polarizer **100b** and is seen by the viewer as a bright R sub-pixel **204**. The display **200** is normally white because the pixels are in bright states when no pixel voltage is applied to the pixels.

Referring to FIG. 11B, when a pixel voltage $V_{DATA}=V_{DARK}$ that corresponds to the dark state is applied to the electrodes 103 and 106, the liquid crystal molecules 128 become substantially aligned along a direction normal to the surfaces of the substrates 102a and 102b. In the R sub-pixel 204, the polarization of the linearly polarized light 134 does not change as the light 134 passes the liquid crystal layer 202. Because the light 134 has a polarization perpendicular to the lengthwise direction of the metal strips 120 of the wire grid polarizer 108, the light 134 passes the wire grid polarizer 108 and is absorbed by the lower polarizer 101a. The viewer sees a dark R sub-pixel 204. In the T sub-pixel 206, the linearly polarized light 132 maintains its polarization as it passes the liquid crystal layer 202, and is blocked by the upper polarizer 101b. The viewer sees a dark T sub-pixel 206.

Although the passivation layer 208 causes the percentage of the pixel voltage V_{DATA} applied to the R and T sub-pixels 202 and 206 to be different, the pixel voltage $V_{DATA}=V_{DARK}$ is selected to be sufficiently high such that the liquid crystal molecules 128 in both the R and T sub-pixels are substantially vertical to the surfaces of the substrates 102a and 102b.

FIG. 12 shows a diagram of an equivalent circuit of the pixel 202 in FIG. 10. The portion of the liquid crystal layer 202 in the R sub-pixel 204 has an effective capacitance that is represented by a capacitor C_{LCR} (210). The portion of the liquid crystal layer 202 in the T sub-pixel 206 has an effective capacitance that is represented by a capacitor C_{LCT} (212). The passivation layer 208 has an effective capacitance represented by a capacitor C_D (214). The pixel voltage V_{DATA} is substantially fully applied to the liquid crystal layer 202 in the T sub-pixel 206. By comparison, because C_D is connected in series with C_{LCR} , only a portion of the pixel voltage V_{DATA} is applied to the portion of the liquid crystal layer 202 in the R sub-pixel 204.

FIG. 13 is a graph 220 showing a curve 222 that represents the voltage-transmittance characteristics of the T sub-pixel 206. Also shown are curves 224, 226, 228, and 230 representing the voltage-reflectance characteristics of the R sub-pixel 204 when the passivation layer 208 has a thickness of 0, 320 nm, 480 nm, and 640 nm, respectively. The data points for the graph 220 were obtained using simulation. When the thickness d_2 of the passivation layer 208 is equal to 480 nm, the curve 228 more closely matches the curve 222 (as compared to the curve 224 versus curve 222), indicating that the voltage-transmittance characteristic of the T sub-pixel 206 more closely matches the voltage-reflectance characteristic of the R sub-pixel 204. The R sub-pixel 204 and the T sub-pixel 206 will show similar gray scale (or color) for a given pixel voltage V_{DATA} .

In the simulations used to obtain the data for the graph 220, the liquid crystal material used was ZLI-4792, available from Merck, Japan. The liquid crystal material has a parallel dielectric constant $\epsilon_{\parallel}=8.3$, perpendicular dielectric constant $\epsilon_{\perp}=3.1$, and elastic constants $K_{11}=13.2$ pN, $K_{33}=6.5$ pN, and $K_{33}=18.3$ pN. The liquid crystal material has an extraordinary refractive index $n_e=1.5763$ and an ordinary refractive index $n_o=1.4794$ at $\lambda=589$ nm. The parameter $d\Delta n$ of the liquid crystal layer 104 is set at 0.48 μm . The passivation layer 105 can be made of dielectric materials (e.g., SiO_2 , which has a dielectric constant of 3.9) that are compatible with the thin film transistor fabrication process.

The thickness of the passivation layer 208 of FIG. 10 can be estimated using a voltage shifting method, similar to that for the passivation layer 105 of FIG. 1. FIG. 14 is a graph 240 that shows curves 222 and 224 representing the voltage-transmittance characteristics of the T sub-pixel 206 and the voltage-reflectance characteristics of the R sub-pixel 204, respec-

tively, when the passivation layer 208 has a thickness $d_2=0$. If the curve 224 is shifted towards the right of the figure, the curves 222 and 224 will more closely match each other. This means that for a given gray scale, the voltage level applied to the R sub-pixel 204 should be lower by a certain amount ΔV than the voltage level applied to the T sub-pixel 206. The thickness of the passivation layer 208 in FIG. 10 can be calculated using a method similar to that for calculating the thickness of the passivation layer 105 in FIG. 1.

FIG. 15 is a cross-sectional diagram of an example of a transmissive liquid crystal display 250 that is similar to the transmissive liquid crystal display 200 of FIG. 10, except that in the R sub-pixel 204 of the display 250, the passivation layer 208 is positioned between the upper electrode 106 and the upper alignment layer 107b. The lower electrode 103 is directly adjacent to the lower alignment layer 107a. In the display 250, similar to the display 200, when a pixel voltage V_{DATA} is applied to the electrodes 103 and 106, the percentage of the pixel voltage V_{DATA} applied to the liquid crystal layer 202 in the R sub-pixel 204 is lower than that in the T sub-pixel 206.

The viewing angles of the displays 100 (FIG. 1), 190 (FIG. 9), 200 (FIG. 10), and 250 (FIG. 15) can be expanded by adding a compensation film between the upper substrate 102b and the upper polarizer 101b.

FIG. 16A is an iso-contrast plot 260 for an example of the display 100 (FIG. 1), in which a compensation film was not used. In this example, the display 100 included a liquid crystal material MLC-6608, available from Merck, Japan, in which the $d\Delta n$ parameter of the liquid crystal material equals 0.36 μm . The display 100 can achieve 10:1 contrast ratio over 40 degrees in most directions.

FIG. 16B is an iso-contrast plot 270 for an example of the display 100 (FIG. 1), in which a compensation film was used to compensate light leakage from the liquid crystal phase retardation at off-axis angles. The compensation film used in this example is a negative C film with refractive indices $n_o=1.5110$, and $n_e=1.5095$, and the parameter $d\Delta n$ of the negative C film is 0.36 μm . The $d\Delta n$ value for the liquid crystal layer and the C film are set to be equal so that the off-axis phase retardation from the liquid crystal layer cancels the off-axis phase retardation from the C film. With the addition of a compensation film, the display 100 has a 10:1 contrast ratio over 60 degrees in most directions.

FIG. 17 is a diagram of an example of the liquid crystal display 100, in which the figure shows an array 12 of pixels 110 that are controlled by one or more gate drivers 16 and one or more data drivers 18. Each pixel 110 includes one or more thin film transistors (TFT) 148, a storage capacitor C_{ST} 146, and other components shown in FIG. 1.

In a color display, each pixel 110 can have a red, green, or blue filter to show red, green, or blue color, respectively. A red pixel, a green pixel, and a blue pixel can together generate a color image pixel. By controlling the gray scale levels of the red, green, and blue pixels, each color image pixel can display a wide range of colors and gray scale levels.

Other implementations and applications are also within the scope of the following claims. For example, in FIG. 17, the pixels 110 can be replaced by other types of pixels, such as those shown in FIGS. 9, 10, and 15. Additional passivation layers and alignment layers can be used in the displays described above. The materials used for the components of the displays, such as the liquid crystal layer, the polarization films, and the compensation films, can use materials and have parameters different from those described above. The retardation values $d\Delta n$ of the films can be different from those described above. Compensation films different from those

described above can be used. In some examples, a negative C film or a positive O film can be used as a compensation film. Other compensation films are described in “Analytical solutions for uniaxial-film-compensated wide-view liquid crystal displays” by X. Zhu et al, Journal of Display Technology, vol. 2, pages 2-20, 2006, herein incorporated by reference. When the display is operating in the transmissive mode in which the backlight module is turned on, some ambient light may be reflected by the transflector, so the display can operate in both the transmissive and reflective modes at the same time.

In the description above, the terms “upper” and “lower” are used to describe relative positions of components as shown in the figures. The display can have various orientations, so for example, an upper film may be positioned below a lower film depending on the orientation of the display. The orientations of the liquid crystal molecules described above refer to the directions of directors of the liquid crystal molecules. The molecules do not necessarily all point to the same direction all the time. The molecules may tend to point more in one direction (represented by the director) over time than other directions. For example, the phrase “the liquid crystal molecules are substantially aligned along a direction normal to the substrates” means that the average direction of the directors of the liquid crystal molecules is generally aligned along the normal direction, but the individual molecules may point to different directions.

What is claimed is:

1. A display comprising:
 - a plurality of normally dark pixel circuits each comprising:
 - a first electrode;
 - a second electrode;
 - a reflective region to reflect ambient light, the reflective region comprising a first portion of a liquid crystal layer between the first and second electrodes, and a polarization dependent reflector that transmits light having a first polarization and reflects light having a second polarization;
 - a transmissive region to transmit backlight, the transmissive region comprising a second portion of the liquid crystal layer between the first and second electrodes;
 - a dielectric layer between the first and second electrodes in the transmissive region, the dielectric layer configured such that when a pixel voltage is applied to the first and second electrodes, the percentage of the pixel voltage applied across the first portion of the liquid crystal layer is higher than the percentage of the pixel voltage applied across the second portion of the liquid crystal layer; and
 - a backlight module to generate the backlight wherein the dielectric layer and the polarization dependent reflector face the same side of the liquid crystal layer.
2. The display of claim 1 wherein the polarization dependent reflector comprises a wire grid polarizer.
3. The display of claim 1 wherein the liquid crystal layer is between two substrates, and the liquid crystal layer comprises liquid crystal molecules that are substantially aligned along a direction normal to the substrates when no voltage is applied to the first and second electrodes.
4. The display of claim 1 wherein the dielectric layer has a dielectric constant and a thickness that are selected to reduce a difference between a transmittance of the transmissive region and a reflectance of the reflective region for a given pixel voltage applied to the first and second electrodes.
5. The display of claim 1 wherein the dielectric layer has an effective capacitance that is connected in series with an effective capacitance of the liquid crystal layer between the first and second electrodes.

6. The display of claim 1 wherein the dielectric layer comprises at least one of silicon oxide and silicon nitride.

7. The display of claim 1 wherein at least one of the first electrode and the second electrode comprises at least one of indium tin oxide, indium zinc oxide, and gallium zinc oxide.

8. The display of claim 1, further comprising a first linear polarizer and a second linear polarizer that both extend over the transmissive and reflective regions, the first and second linear polarizers being at different sides of the liquid crystal layer.

9. The display of claim 8 wherein the first linear polarizer is closer to a viewer than the second linear polarizer, and the polarization dependent reflector has a reflective axis that is perpendicular to a transmission axis of the first linear polarizer.

10. The display of claim 1 wherein the liquid crystal layer comprises a negative dielectric anisotropic liquid crystal material.

11. The display of claim 1 wherein the liquid crystal layer comprises a positive dielectric anisotropic liquid crystal material.

12. The display of claim 1 in which the polarization dependent reflector is closer to the second electrode than the first electrode, and the dielectric layer is between the second electrode and the liquid crystal layer.

13. A display comprising:

- a first substrate;
- a second substrate;
- normally dark pixel circuits between the first and second substrates, each pixel circuit having a transmissive region and a reflective region, each pixel circuit comprising:
 - a first electrode;
 - a second electrode;
 - a liquid crystal layer between the first and second electrodes, the liquid crystal layer having a first portion located at the reflective region and a second portion located at the transmissive region;
 - a polarization dependent reflector located at the reflective region; and
 - a dielectric layer located at the transmissive region, wherein the dielectric layer has an effective capacitance that is connected in series with an effective capacitance of the liquid crystal layer between the first and second electrodes, the dielectric layer is configured such that when a pixel voltage is applied to the first and second electrodes, the percentage of the pixel voltage applied across the first portion of the liquid crystal layer is higher than the percentage of the pixel voltage applied across the second portion of the liquid crystal layer;
- wherein the dielectric layer and the polarization dependent reflector face the same side of the liquid crystal layer.

14. The display of claim 13 wherein the dielectric layer is configured to cause a gray scale gamma curve of the transmissive region to more closely match a gray scale gamma curve of the reflective region, as compared to the pixel circuit without the dielectric layer.

15. The display of claim 13 in which the polarization dependent reflector is closer to the second electrode than the first electrode, and the dielectric layer is between the second electrode and the liquid crystal layer.

16. The display of claim 13 wherein the liquid crystal layer is between the first and second substrates, and the liquid crystal layer comprises liquid crystal molecules that are sub-

15

stantially aligned along a direction normal to the first and second substrates when no voltage is applied to the first and second electrodes.

17. A transfective display comprising:

a first linear polarizer having a first transmission axis;

a second linear polarizer having a second transmission axis, the first linear polarizer located closer to a front side of the display than the second linear polarizer;

normally dark pixel circuits each comprising:

a first electrode;

a second electrode;

a liquid crystal layer between the first and second linear polarizers, the liquid crystal layer having a first portion between the first and second electrodes and a second portion between the first and second electrodes, the first portion corresponding to a reflective region of the pixel circuit, the second portion corresponding to a transmissive region of the pixel circuit;

a storage capacitor to store an electric charge corresponding to a pixel voltage;

a polarization dependent reflector that is associated with the first portion of the liquid crystal layer, the polarization dependent reflector to reflect a first component of external light and transmit a second component of the external light, the first component having a first polarization substantially perpendicular to the first

16

transmission axis and the second component having a second polarization substantially parallel to the first transmission axis; and

a dielectric layer disposed in the transmissive region of the pixel circuit, the dielectric layer configured between the first and second electrodes such that when the pixel voltage is applied to the first and second electrodes, the percentage of the pixel voltage applied across the first portion of the liquid crystal layer is higher than the percentage of the pixel voltage applied across the second portion of the liquid crystal layer;

wherein the dielectric layer and the polarization dependent reflector face the same side of the liquid crystal layer.

18. The display of claim **17** wherein the dielectric layer is configured to cause the transmissive region to have a transmittance-voltage characteristic that more closely matches a reflectance-voltage characteristic of the reflective region, as compared to a pixel circuit that applies the same percentage of the pixel voltage to the first and second portions of the liquid crystal layer.

19. The display of claim **17** wherein the liquid crystal layer is between two substrates, and the liquid crystal layer comprises liquid crystal molecules that are substantially aligned along a direction normal to the substrates when no voltage is applied to the first and second electrodes.

* * * * *