



US008922739B2

(12) **United States Patent**
Lan et al.

(10) **Patent No.:** **US 8,922,739 B2**
(45) **Date of Patent:** **Dec. 30, 2014**

(54) **LIQUID CRYSTAL DISPLAY WITH PARTICULAR STRUCTURE FOR THE PIXEL ELECTRODE AND THE COMMON ELECTRODE**

(58) **Field of Classification Search**
CPC G02F 1/133528; G02F 1/133536; G02F 1/134363; G02F 1/133707; G02F 1/136213; G02F 1/134336; G02F 1/1393; G02B 5/3033
USPC 349/96, 141, 144, 146
See application file for complete search history.

(71) Applicants: **AU Optronics Corp.**, Hsin-Chu (TW);
University of Central Florida Research Foundation Inc., Orlando, FL (US)

(56) **References Cited**

(72) Inventors: **Yi-Fen Lan**, Hsin-Chu (TW);
Cheng-Yeh Tsai, Hsin-Chu (TW);
Shin-Tson Wu, Orlando, FL (US);
Yi-Fan Liu, Orlando, FL (US)

U.S. PATENT DOCUMENTS

7,199,852 B1 4/2007 Lu
8,111,358 B2 * 2/2012 Shibahara 349/96
2005/0237465 A1 * 10/2005 Lu et al. 349/141
2010/0182558 A1 * 7/2010 Lu et al. 349/141

(73) Assignees: **AU Optronics Corp.**, Science-Based Industrial Park, Hsin-Chu (TW);
University of Central Florida Research Foundation Inc., Orlando, FL (US)

FOREIGN PATENT DOCUMENTS

JP 2010026324 2/2010

* cited by examiner

Primary Examiner — Mike Qi

(74) *Attorney, Agent, or Firm* — Winston Hsu; Scott Margo

(*) Notice: Subject to any disclaimer, the term of this patent is extended or adjusted under 35 U.S.C. 154(b) by 152 days.

(57) **ABSTRACT**

A liquid crystal display includes an upper substrate, a lower substrate, a liquid crystal layer disposed between the upper and lower substrates and including liquid crystal molecules with optical isotropicity, a first polarizer disposed on a surface of the upper substrate, having a first polarization direction, a second polarizer disposed on a surface of the lower substrate, having a second polarization direction, and at least one pixel region defined on the lower substrate. The pixel region includes at least one pixel electrode disposed on the lower substrate, the pixel electrode extending along a first direction in the pixel region and a majority portion of an edge of the pixel electrode substantially being parallel to at least one of the first polarization direction and the second polarization direction.

(21) Appl. No.: **13/729,042**

(22) Filed: **Dec. 28, 2012**

(65) **Prior Publication Data**

US 2014/0184991 A1 Jul. 3, 2014

(51) **Int. Cl.**
G02F 1/1335 (2006.01)
G02F 1/1343 (2006.01)

(52) **U.S. Cl.**
CPC **G02F 1/134309** (2013.01); **G02F 1/134363** (2013.01)
USPC **349/96**; 349/141; 349/144; 349/146

18 Claims, 10 Drawing Sheets

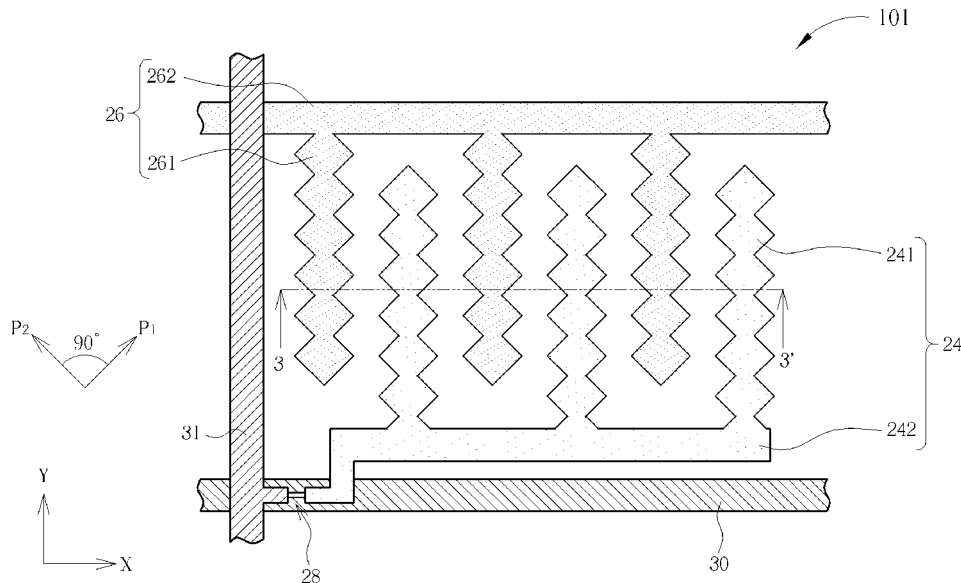

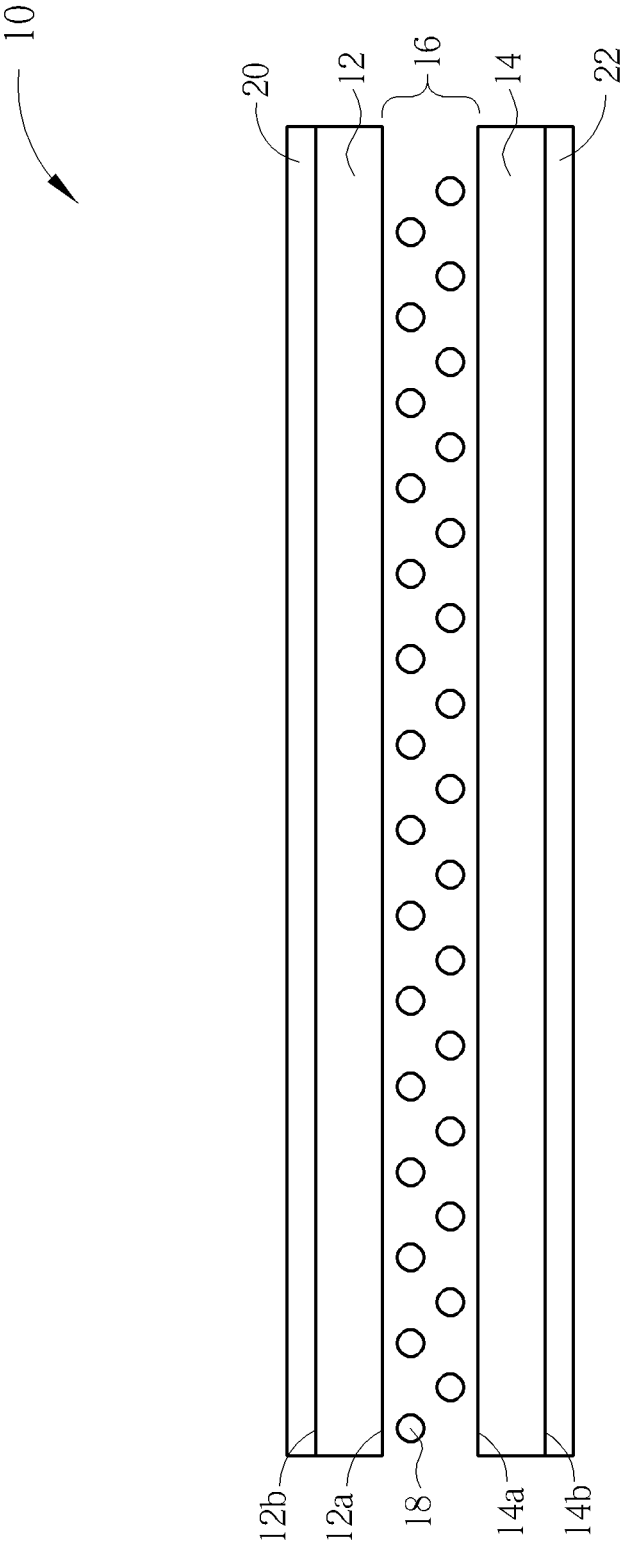

FIG. 1

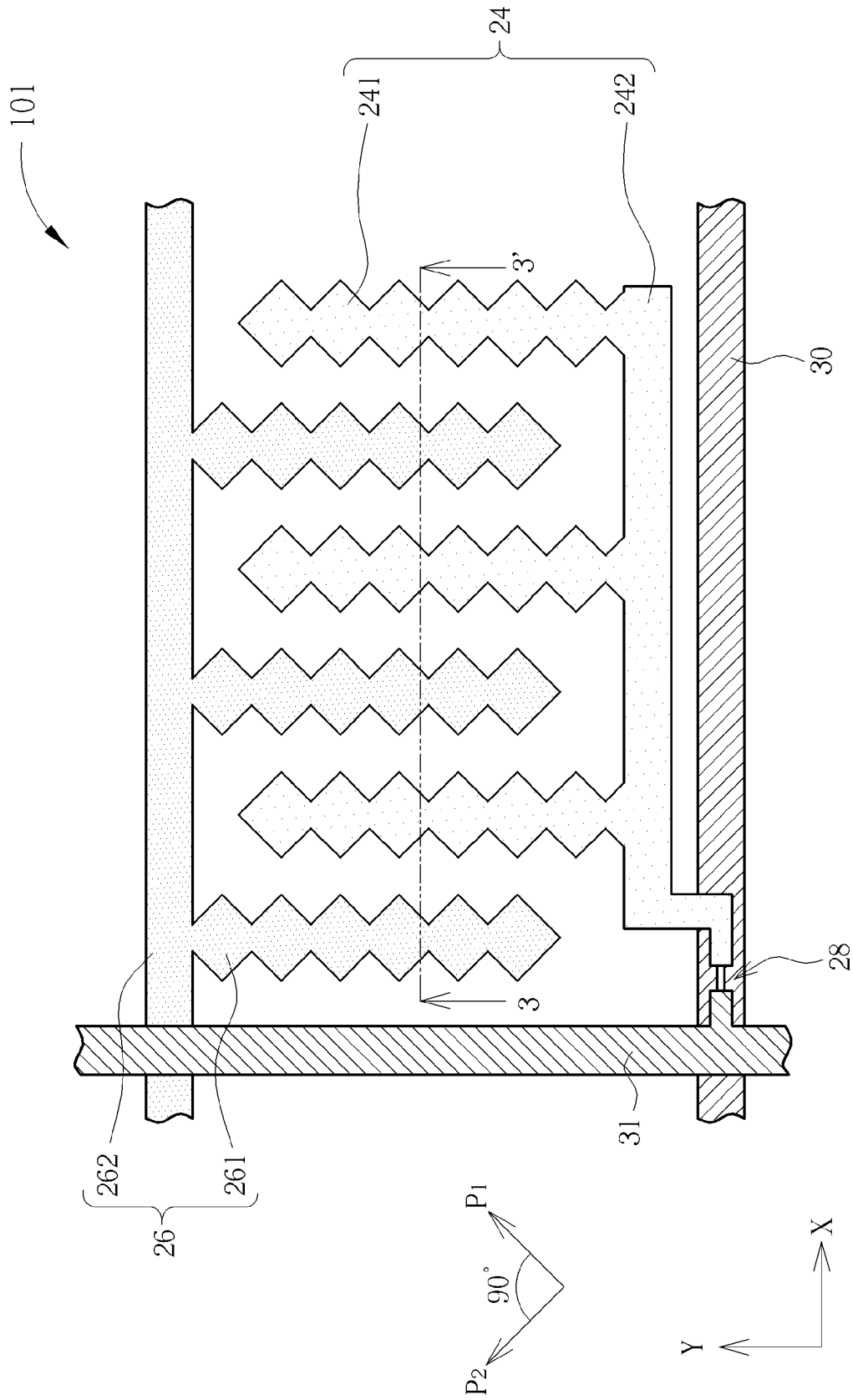

FIG. 2

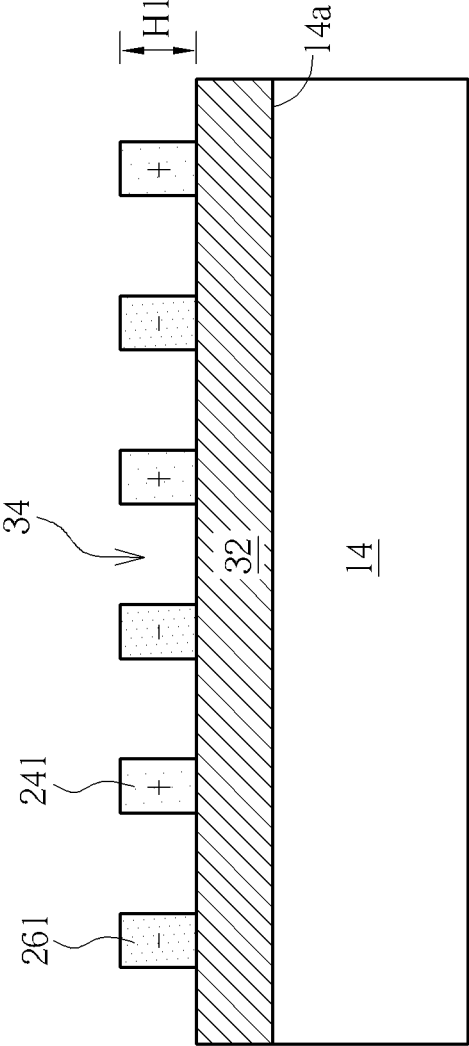

FIG. 3

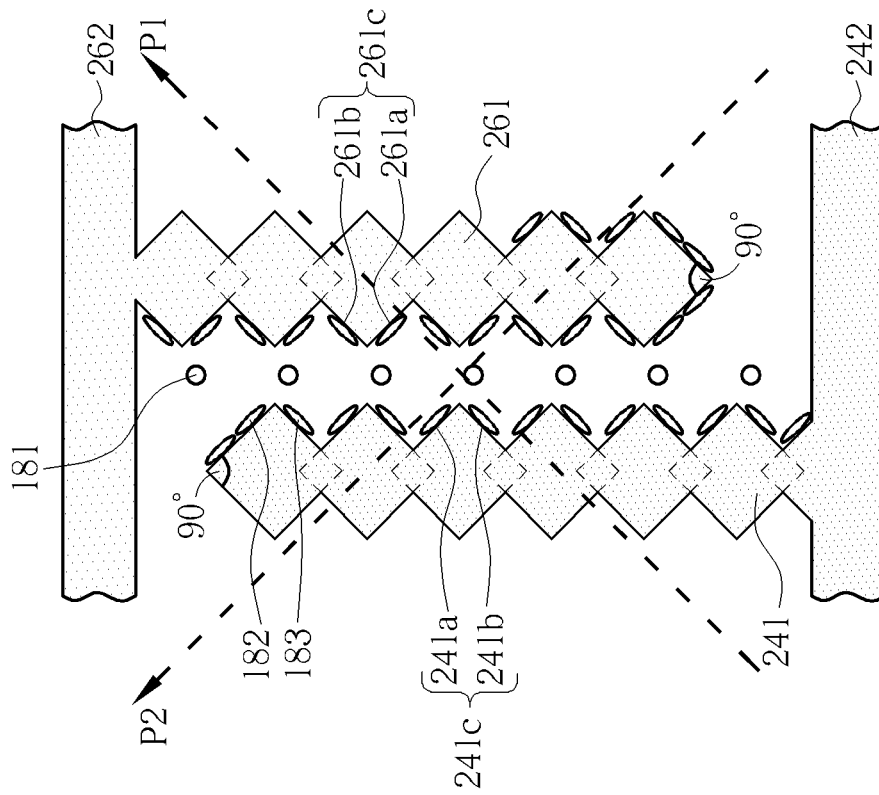

FIG. 4

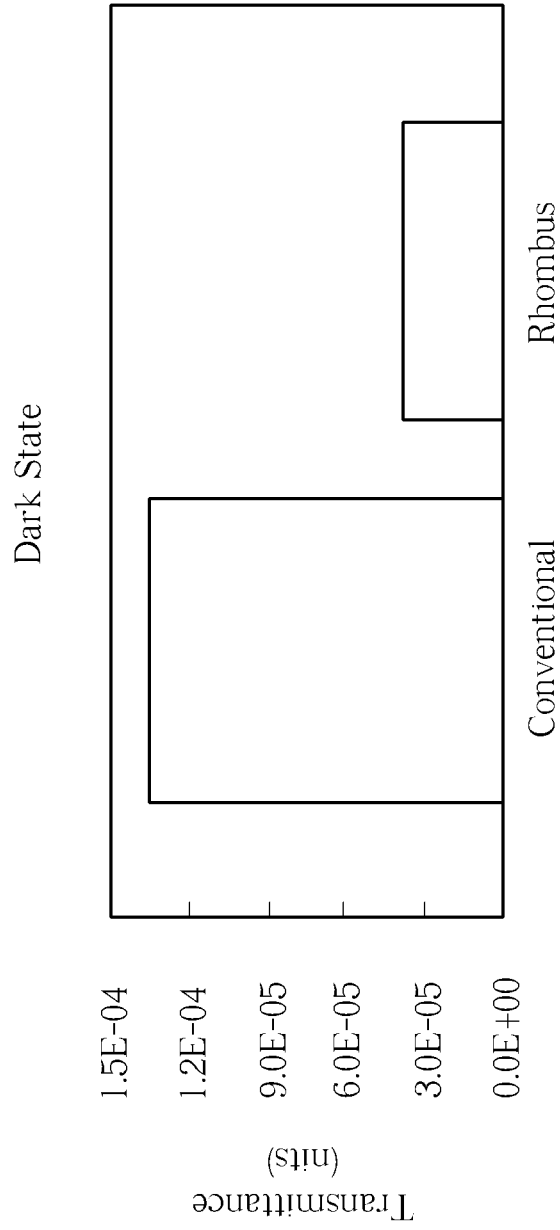

FIG. 5

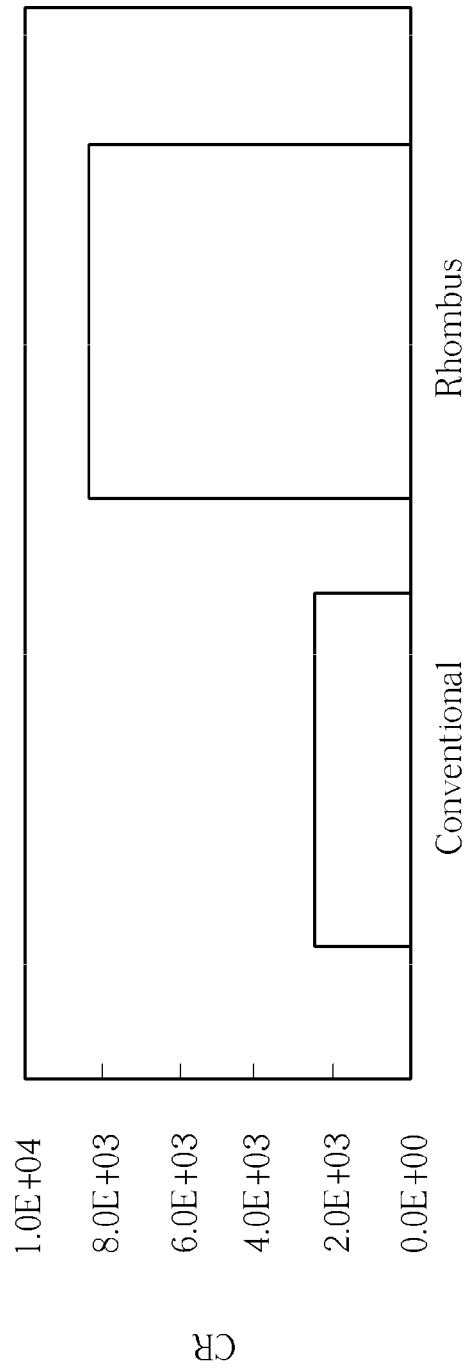

FIG. 6

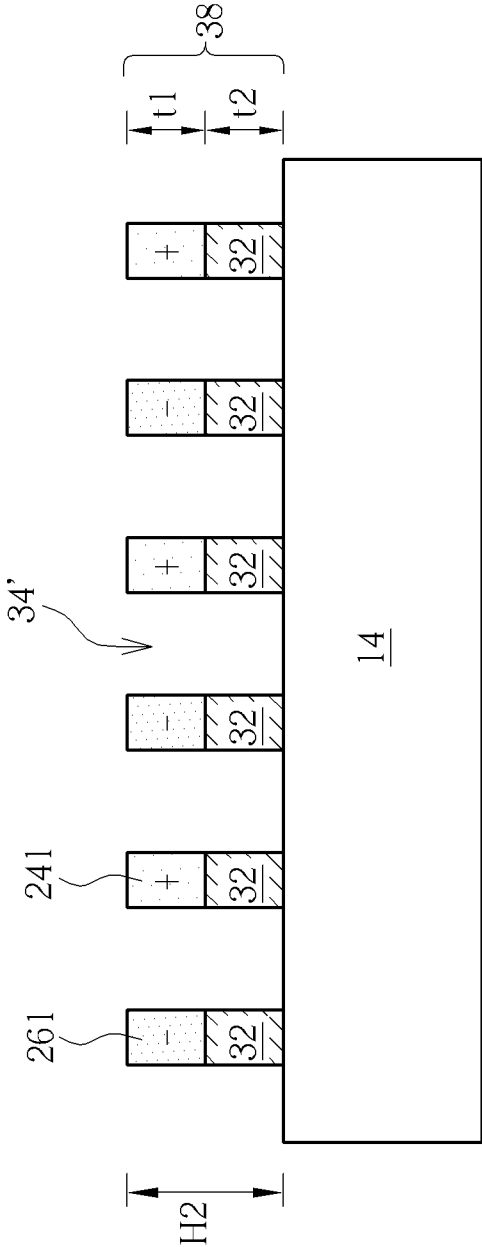

FIG. 7

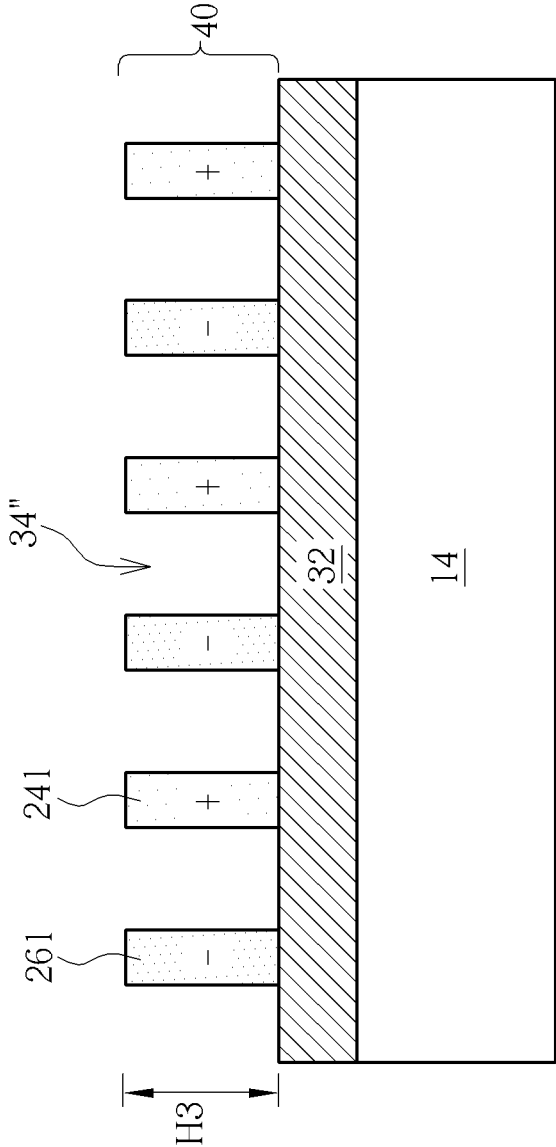

FIG. 8

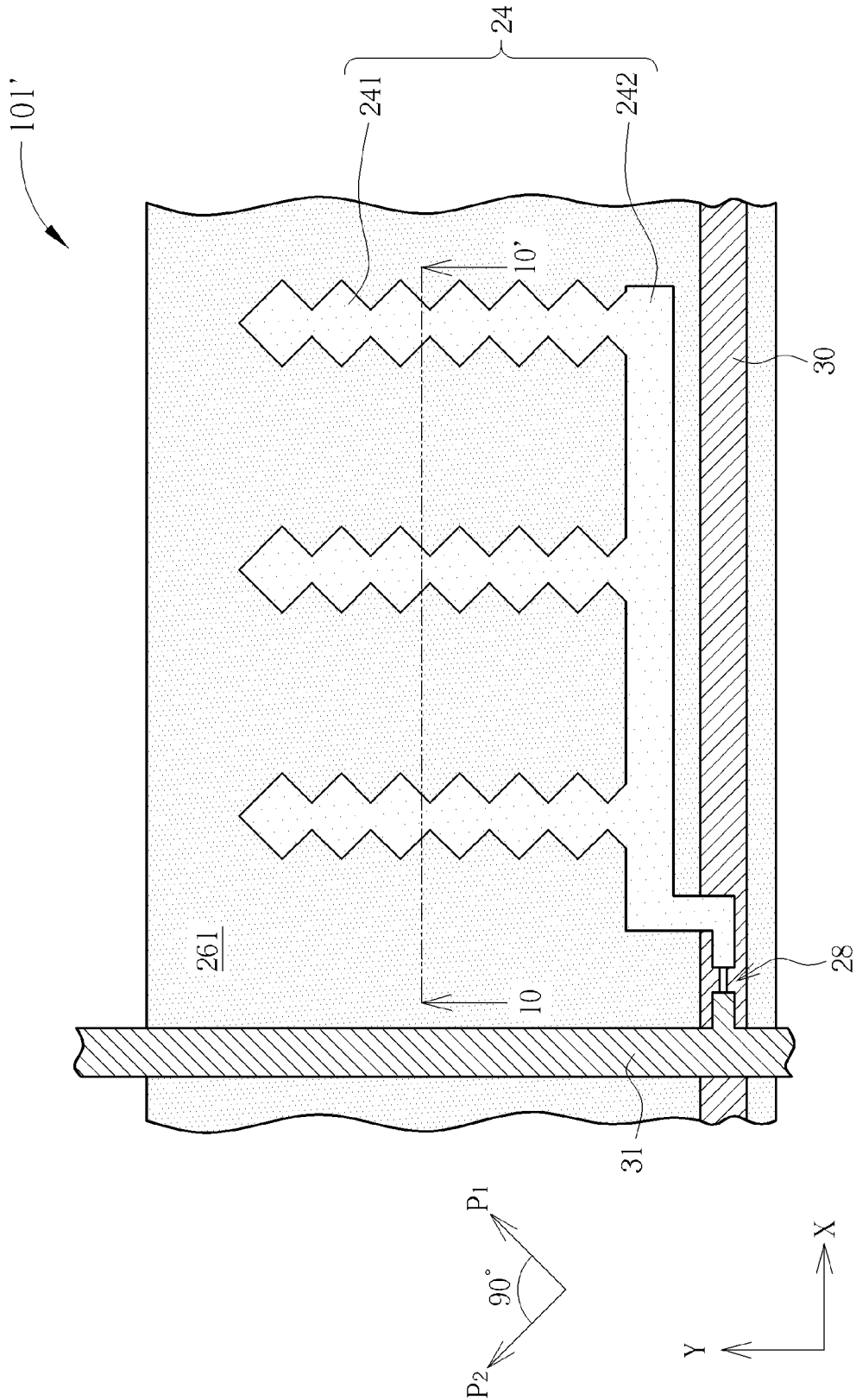

FIG. 9

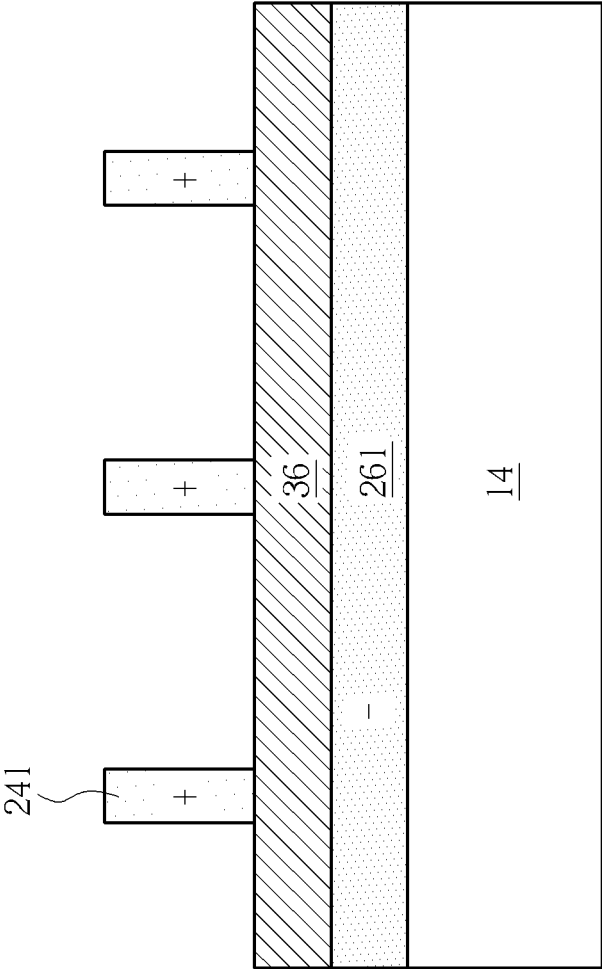

FIG. 10

1

**LIQUID CRYSTAL DISPLAY WITH
PARTICULAR STRUCTURE FOR THE PIXEL
ELECTRODE AND THE COMMON
ELECTRODE**

BACKGROUND OF THE INVENTION

1. Field of the Invention

The present invention is related to a liquid crystal display (LCD), and more particularly, to an LCD including liquid crystal molecules with optical isotropy.

2. Description of the Prior Art

LCD has been widely applied to many display devices. One of the key elements of an LCD is the liquid crystal layer with liquid crystal molecules. The conventional liquid crystal molecules used in the LCD have a property of optical anisotropy under room temperature and have oval-shaped shapes. However, a type of liquid crystal molecules with optical isotropy under room temperature, such as blue phase liquid crystal (BPLC) molecules is a new research field for LCD manufacturer. An example of the BPLC molecules is cholesteryl benzoate molecules.

Generally, in a BPLC in-plane switch (IPS) LCD panel, the panel has a black state if no voltage is supplied because of the optical isotropy of the BPLC molecules, which is called normal black state. In contrast, when a voltage is applied to the electrodes of the BPLC IPS LCD panel, the shapes of the BPLC molecules will be deformed so as to have optical anisotropy and birefringence, such that the panel displays a white state. However, due to compression and molecules' alignment property, the BPLC molecules also are deformed by the electrodes even no voltage is applied. The BPLC molecules near the electrodes line along the sidewalls or edges of the electrodes so that they also have oval-shaped shapes with optical anisotropy and birefringence. As a result, light leakage occurs along the edge or shapes of the electrodes when the panel is under dark state, and therefore the contrast of the display panel is influenced.

SUMMARY OF THE INVENTION

It is therefore one of the objectives of the present invention to provide an LCD having liquid crystal molecules with optical isotropy and good contrast by designing the electrodes with specific shapes.

According to an embodiment of the present invention, an LCD includes an upper substrate, a lower substrate, and a liquid crystal layer disposed between the upper and lower substrates and including liquid crystal molecules with optical isotropy. The LCD further includes a first polarizer disposed on a surface of the upper substrate and having a first polarization direction, a second polarizer disposed on a surface of the lower substrate and having a second polarization direction, and at least one pixel region defined on the lower substrate. The pixel region includes at least one pixel electrode disposed on the lower substrate, the pixel electrode extending along a first direction in the pixel region and a majority portion of an edge of the pixel electrode substantially being parallel to at least one of the first polarization direction and the second polarization direction.

Since the majority portion of the edge of the pixel electrode is substantially parallel to at least one of the first polarization direction and the second polarization direction, the liquid crystal molecules near the pixel electrodes will also line along at least one of the first and the second polarization directions. Therefore, even light passes through these liquid crystal mol-

2

ecules is polarized, it still hardly emits out the LCD panel, so as to solve the problem of light leakage in the prior art and to improve the display contrast.

These and other objectives of the present invention will no doubt become obvious to those of ordinary skill in the art after reading the following detailed description of the preferred embodiment that is illustrated in the various figures and drawings.

BRIEF DESCRIPTION OF THE DRAWINGS

FIG. 1 is a cross-view schematic diagram of an LCD of the present invention.

FIG. 2 is a schematic diagram of a top view of a pixel region of the LCD shown in FIG. 1.

FIG. 3 is a sectional view of FIG. 2 along a sectional line 3-3'.

FIG. 4 is a partial enlargement figure of the pixel electrode and the common electrode shown in FIG. 2.

FIG. 5 is a diagram of the transmittances of a conventional BPLC IPS LCD and the present invention BPLC IPS LCD with rhombus shape electrodes under dark state.

FIG. 6 is a diagram of the contrast (CR) of the conventional BPLC IPS LCD and the present invention BPLC IPS LCD with rhombus shape electrodes.

FIG. 7 is a sectional schematic diagram of the pixel electrodes and common electrodes corresponding to the sectional line 3-3' in FIG. 2 according to a first variation embodiment of the first embodiment.

FIG. 8 is a sectional schematic diagram of the pixel electrodes and common electrodes corresponding to the sectional line 3-3' of FIG. 2 according to a second variation embodiment of the first embodiment.

FIG. 9 is a schematic diagram of a top view of a pixel region of an LCD according to a second embodiment of the present invention.

FIG. 10 is a sectional view of FIG. 9 along a sectional line 10-10'.

DETAILED DESCRIPTION

Referring to FIG. 1, FIG. 1 is a cross-view schematic diagram of an LCD of the present invention. According to a first embodiment, the LCD 10 is an IPS LCD panel, including an upper substrate 12, a lower substrate 14 disposed below the upper substrate 12, a liquid crystal layer 16 disposed between the upper and lower substrates. The liquid crystal layer 16 includes liquid crystal molecules 18 with optical isotropy. In this embodiment, the liquid crystal molecules 18 are BPLC molecules, such as cholesteryl benzoate molecules, and they have spherical shapes under room temperature. The LCD 10 further includes a first polarizer 20 having a first polarization direction P1 and a second polarizer 22 having a second polarization direction P2. The first polarizer 20 and the second polarizer 22 are disposed near the upper substrate 12 and the lower substrate 14 respectively. For example, the first polarizer 20 is disposed on an upper surface 12b of the upper substrate 12, and the second polarizer 22 is disposed on the lower surface 14b of the lower substrate 14. In this embodiment, the first polarization direction P1 is perpendicular to the second polarization direction P2, but not limited thereto. In other embodiments, the first polarization direction P1 may be parallel to the second polarization direction P2.

Please refer to FIG. 2 and FIG. 3, wherein FIG. 2 is a schematic diagram of a top view of a pixel region of the LCD 10 shown in FIG. 1, and FIG. 3 is a sectional view of FIG. 2 along a sectional line 3-3'. The LCD 10 includes at least one

pixel region **101** defined on the lower substrate **14**. Preferably, the LCD **10** includes a plurality of pixel regions **101** arranged as an array. The pixel region **101** includes at least one data line **31** extending along a first direction **Y** and at least one gate line **30** extending along a second direction **X**. A thin film transistor **28** is disposed at the cross portion of the gate line **30** and the data line **31**. The pixel region **101** further includes at least one pixel electrode **241** extends along the first direction **Y**. In this embodiment, the pixel region **101** includes a plurality of pixel electrodes **241**. For example, FIG. 2 shows three pixel electrodes **241** in one pixel region **101**. The pixel electrodes **241** are electrically connected to each other through a pixel electrode bar **242** extending along the second direction **X**, and the pixel electrodes **241** and the pixel electrode bar **242** in the pixel region **101** can be seen as a pixel electrode unit **24**. Since the LCD **10** is an IPS LCD, the pixel region **101** may also include a plurality of common electrodes **261**, extending along the first direction **Y**. The common electrodes **261** are electrically connected to each other through a common electrode bar **262** extending along the second direction **X**, and the common electrodes **261** and the common electrode bar **262** in the pixel region **101** can be seen as a common electrode unit **26**. In this embodiment, the data line **31**, the gate line **30**, the thin film transistor **28**, the pixel electrode unit **24**, and the common electrode unit **26** are disposed on the upper surface **14a** of the lower substrate **14**, but not limited thereto. For example, the common electrode unit **26** may be disposed on the lower surface **12a** of the upper substrate **12** in other embodiments.

As shown in FIG. 3, the common electrodes **261** and the pixel electrodes **241** are disposed alternately and parallel to each other, thus there are several cavities **34** formed between the adjacent common electrodes **261** and the pixel electrodes **241**. The pixel electrodes **241** and the common electrodes **261** are disposed on the upper surface **14a** of the lower substrate **14**, and a passivation layer **32** may be disposed between the pixel and common electrodes **241**, **261** and the lower substrate **14**. The pixel electrode unit **24** and the common electrode unit **26** may be formed with a same conductive layer, preferably a transparent conductive layer, and have a height **H1**. The liquid crystal molecules **18** may fill up the cavities **34** with the height **H1**. For instance, when driving the pixel region **101**, a common voltage (such as a negative voltage, -1.5 volt) may be applied to the common electrodes **261** and a driving voltage (such as a positive voltage, 1.5 volt) may be applied to the pixel electrodes **241** such that a lateral electric field occurs between the pixel electrodes **241** and the common electrodes **261**, especially in the cavities **34**, which drives the liquid crystal molecules **18** to be deformed and have birefringence so as to polarizes light passes through the liquid crystal layer **16**.

As shown in FIG. 2, the first polarization direction **P1** and the second polarization direction **P2** have an included angle of 90° in this embodiment. Taking the second direction **X** being a coordinate with 0° as an example, the first polarization direction **P1** has an included angle 45° with the second direction **X**, and the second polarization direction **P2** has an included angle 135° with the second direction **X**. The first polarization direction **P1** and the second polarization direction **P2** also have an included angle of about 45° with the first direction **Y**. Please refer to FIG. 4 with FIG. 2, wherein FIG. 4 is a partial enlargement figure of the pixel electrode **241** and the common electrode **261** shown in FIG. 2. Each of the pixel electrodes **241** is composed of a plurality of quadrilateral cubes **241c** arranged as a line in series in the pixel region **101**, wherein the line is parallel to the first direction **Y**, and at least one portion of each of the quadrilateral cubes **241c** in the

same series is overlapped by an adjacent quadrilateral cube **241c**, as shown in the dotted lines. Preferably, the quadrilateral cubes **241c** are parallelogram cubes. Two sides **241a** of each quadrilateral cube **241c** are parallel to each other, and the other two sides **241b** of the quadrilateral cube **241c** are parallel to each other. Moreover, the two sides **241a** are parallel to the second polarization direction **P2**, and the other two sides **241b** are parallel to the first polarization direction **P1**. Accordingly, any two adjacent sides **241a** and **241b** of each quadrilateral cubes **241c** have an included angle of 90° . In a more preferable embodiment, the quadrilateral cubes **241c** are rhombus cubes or square cubes, which means the sides **241a** and the sides **241b** have identical length. As a result, the majority portion of the edge of each pixel electrode **241** is substantially parallel to at least one of the first polarization direction **P1** and the second polarization direction **P2**. Specifically, according to this embodiment, about a half majority portion of the edge of each pixel electrode **241** is parallel to the first polarization direction **P1**, such as the sides **241b**, and the other half majority portion of the edge of each pixel electrode **241** is parallel to the second polarization direction **P2**, such as the sides **241a**. Similarly, each of the common electrodes **261** is composed of a plurality of quadrilateral cubes **261c** arranged as a line in series in the pixel region **101**, wherein the line is parallel to the first direction **Y**, and at least one portion of each of the quadrilateral cubes **261c** in the same series is overlapped by an adjacent quadrilateral cube **261c**.

Two sides **261a** of each quadrilateral cube **261c** are parallel to the second polarization direction **P2**, and the other two sides **261b** are parallel to the first polarization direction **P1**. Preferably, the quadrilateral cubes **261c** are rhombus cubes or square cubes, and the sides **261a** and the sides **261b** have identical length. More preferably, the quadrilateral cubes **261c** and the quadrilateral cubes **241c** have the same sizes.

FIG. 4 also shows the arrangement of the BPLC molecules **181**, **182**, **183** between the pixel and common electrodes **241**, **261** when no voltage is applied. The sizes and number of the BPLC molecules **181**, **182**, **183** relative to the sizes of the quadrilateral cubes **241c**, **261c** in FIG. 4 are only for explanation, not for limiting the present invention. The BPLC molecules **181** disposed not near the pixel electrode **241** and the common electrode **261** have their usual spherical shape and optical isotropicity. The BPLC molecules **182**, **183** disposed near the majority portion of the edge (sides **241a**, **241b**) of the pixel electrode **241** and the majority portion of the edge (sides **261a**, **261b**) of the pixel electrode **261** are deformed along the edges to have optical anisotropicity. For example, the BPLC molecules **182** near the sides **241a** are deformed to have a long axis arranged along the sides **241a**, which are parallel to the second polarization direction **P2**, and the BPLC molecules **183** near the sides **241b** are deformed to have a long axis arranged along the sides **241b**, parallel to the first polarization direction **P1**. Assume light emits from the lower side of the LCD **10** and first passes through the second polarizer **22** and become a polarized light with the second polarization direction **P2**. Since the long axes of the BPLC molecules **182**, **183** are aligned along the first polarization direction **P1** or the second polarization direction **P2**, the polarized light passes through the BPLC molecules **182**, **183** will still remain as polarized light with the second polarization direction **P2**. Therefore, the light leakage near the edges of the electrodes under the dark state occurred in the prior art LCD panel can be effective suppressed.

It should be noted that the pixel and common electrodes **241** and **261** may not always have the sharp corners between the sides **241a** and **241b** or between the sides **261a** and **261b**

shown in FIG. 2 and FIG. 4 practically because of process limitation, process window and formation inaccuracy. For example, after photolithography and development processes, the included angle of the sides **241a** and **241b** and the included angles of the sides **261a** and **261b** may have round corners. Therefore, the majority portion of the edges of the pixel electrodes **241** and common electrodes **261** is substantially parallel to the first polarization direction **P1** or the second polarization direction **P2** means that the sides **241a**, **261a** may have an included angle with the second polarization direction **P2** less than or equal to $\pm 4^\circ$ and the sides **241b**, **261b** may have an included angle with the first polarization direction **P1** less than or equal to $\pm 4^\circ$. In other words, the situation that the included angle of the edges of the pixel and common electrodes **241**, **261** and the second polarization direction **P2** or the first polarization direction **P1** is $0^\circ \pm 4^\circ$ still meets the meaning "substantially parallel" in the above description. In another aspect, when most tangent lines of the edges of the pixel electrodes **241** or the common electrodes **261** are parallel to at least one of the first and second polarization directions **P1**, **P2** or have included angles less than or equal to $\pm 4^\circ$, it also meets the description that the majority portion of the edges of the pixel electrodes **241** and common electrodes **261** is substantially parallel to at least one of the first and second polarization directions **P1**, **P2**.

FIG. 5 is a diagram showing the transmittances of a conventional BPLC IPS LCD and the present invention BPLC IPS LCD with rhombus shape electrodes under dark state. As shown in FIG. 5, the conventional BPLC IPS LCD has a transmittance of more than 1.2×10^{-4} nits under normal dark state, and the BPLC IPS LCD with rhombus shape electrodes according to the first embodiment of the present invention only has a transmittance less than 5×10^{-5} nits. FIG. 6 is further illustrates a diagram showing the contrast (CR) of the conventional BPLC IPS LCD and the present invention BPLC IPS LCD with rhombus shape electrodes.

As shown in FIG. 6, the conventional BPLC IPS LCD only has a contrast less than 3×10^3 , and the BPLC IPS LCD with rhombus shape electrodes according to the first embodiment of the present invention has a contrast higher than 8×10^3 . Accordingly, the present invention BPLC IPS LCD has a better performance than the conventional BPLC IPS LCD, whether regarding light leakage problem or the display contrast. Furthermore, since the pixel electrodes **241** and the common electrodes **261** have curved and bending edges, they provided a multi-domain effect to the liquid crystal molecules **18** such that the gamma shift can be improved. According to the first embodiment of the present invention, the maximum gamma shift is about 7%, and the maximum gray level inversion is about 5%. Accordingly, the present invention LCD **10** not only has good contrast but also have low gamma shift.

The LCD structure of the present invention is not limited by the aforementioned embodiment, and may have other different preferred embodiments and variation embodiments. To simplify the description, the identical components in each of the following embodiments are marked with identical symbols. For making it easier to compare the difference between the embodiments, the following description will detail the dissimilarities among different embodiments and the identical features will not be redundantly described.

Please refer to FIG. 7, which shows a sectional schematic diagram of the pixel electrodes **241** and common electrodes **261** corresponding to the sectional line 3-3' in FIG. 2 according to a first variation embodiment of the first embodiment. In this variation embodiment, the pixel region **101** has a groove structure **38** that the passivation layer **32** disposed below the pixel electrodes **241** and the common electrodes **261** has

many slits corresponding to the spacing between the adjacent pixel electrodes **241** and common electrodes **261**. In other words, the slits of the passivation layer **32** are corresponding to the edges of the pixel electrodes **241** and the common electrodes **261**. Therefore, the cavities **34'** disposed between the pixel electrodes **241** and common electrodes **261** have a height **H2** which is the sum of the thickness **t1** of the pixel electrodes **241** and the common electrodes **261** and the thickness **t2** of the passivation layer **32**. For example, the thickness **t1** is about 400 angstroms (\AA) and the thickness **t2** is about 2000 \AA , thus the height **H2** of the groove structure **38** is about 2400 \AA , but not limited thereto. In some embodiments, the height **H2** is about 0.04 micrometers (μm) to 5 μm and preferable about 1 μm to 1.5 μm . In other embodiments, the passivation layer **32** may have a thickness **t2** more than 2000 \AA or the thickness **t1** is less than 1 μm .

Please refer to FIG. 8. FIG. 8 is a sectional schematic diagram of the pixel electrodes **241** and common electrodes **261** corresponding to the sectional line 3-3' of FIG. 2 according to a second variation embodiment of the first embodiment. In this variation embodiment, the pixel region **101** has a protrusion structure **40**, wherein the thickness of the pixel electrodes **241** and common electrodes **261** is greater than that in the first embodiment. Therefore, the cavities **34''** between the pixel electrodes **241** and common electrodes **261** have a height **H3** greater than the height **H1** shown in FIG. 3. For example, the thickness of the pixel electrodes **241** and the common electrodes **261** in this variation embodiment may be about 0.04 μm to 5 μm and preferable about 1 μm to 1.5 μm . In some embodiments, the height **H3** is about two times the height **H1** shown in FIG. 3, so as to form the protrusion structure **40**.

In the first and second variation embodiments, both the cavities **34'** and the cavities **34''** have higher height **H2** and height **H3** than the cavities **34** in FIG. 3. Therefore, they have more spaces to containing the BPLC molecules. Accordingly, the effective lateral electrical field occurred between the adjacent pixel electrodes **241** and common electrodes **261** covers greater range to drive the BPLC molecules when voltages are supplied to the pixel electrodes **241** and common electrodes **261**, thus the voltage supply can be saved. For example, the supplied voltage for the pixel electrodes **241** and common electrodes **261** may be less than that in the first embodiment, so as to save the power.

FIG. 9 is a schematic diagram of a top view of a pixel region of an LCD according to a second embodiment of the present invention, and FIG. 10 is a sectional view of FIG. 9 along a sectional line 10-10'. In this embodiment, the LCD is a fringe field switching (FFS) LCD. One pixel region **101'** may only have one common electrode **261** which is like a sheet electrode covering the lower substrate **14**, below the pixel electrodes **241**, and an insulating layer **36** or other dielectric layer is disposed between the pixel electrodes **241** and the common electrode **261**. When driving the LCD, two different voltages may be respectively supplied to the common electrode **261** and the pixel electrodes **241** such that an electrical field occurs between the pixel electrodes **241** and the common electrode **261** to drive the liquid crystal molecules **18**. Since the majority portion of the edges of the pixel electrodes **241** are still substantially parallel to either the first polarization direction **P1** or the second polarization direction **P2**, the present invention FFS LCD including the pixel regions **101'** can provide good display contrast and have low gamma shift. Furthermore, the pixel regions **101'** of the present invention FFS LCD may have groove or protrusion structures similar to the cavities **34'** of FIG. 7 and cavities **34''** of FIG. 8.

In conclusion, in the LCD having liquid crystal molecules with optical isotropicity of the present invention, since the most edges or sidewalls of the pixel electrode are parallel to at least one of the polarization directions of the first polarization and the second polarization, the light leakage and the gamma shift can be effectively improved, so as to provide a better display performance with high display contrast.

Those skilled in the art will readily observe that numerous modifications and alterations of the device and method may be made while retaining the teachings of the invention. Accordingly, the above disclosure should be construed as limited only by the metes and bounds of the appended claims.

What is claimed is:

- 1. A liquid crystal display (LCD), comprising:
 - an upper substrate;
 - a lower substrate;
 - a liquid crystal layer, disposed between the upper and lower substrates and comprising liquid crystal molecules with optical isotropicity;
 - a first polarizer disposed on a surface of the upper substrate, having a first polarization direction;
 - a second polarizer disposed on a surface of the lower substrate, having a second polarization direction; and
 - at least one pixel region defined on the lower substrate, wherein the pixel region comprises at least one pixel electrode disposed on the lower substrate, the pixel electrode extending along a first direction in the pixel region and a majority portion of an edge of the pixel electrode substantially being parallel to at least one of the first polarization direction and the second polarization direction.
- 2. The LCD of claim 1, wherein the pixel region further comprises at least one common electrode disposed on the lower substrate, the common electrode extending along the first direction in the pixel region and a majority portion of an edge of the common electrode substantially parallel to at least one of the first polarization direction and the second polarization direction.
- 3. The LCD of claim 2, comprising a plurality of common electrodes and a plurality of pixel electrodes in the pixel region, wherein the common electrodes and the pixel electrodes are disposed alternately and parallel to each other, the common electrodes are electrically connected to each other through a common electrode bar, and the pixel electrodes are electrically connected to each other through a pixel electrode bar.
- 4. The LCD of claim 3, wherein the LCD is an in-plane switching (IPS) LCD.
- 5. The LCD of claim 1, wherein the pixel region further comprises:

at least one common electrode disposed between the pixel electrode and the lower substrate; and
an insulating layer disposed between the pixel electrode and the common electrode.

- 6. The LCD of claim 5, wherein the LCD is a fringe field switching (FFS) LCD.
- 7. The LCD of claim 1, wherein the pixel electrode is composed of a plurality of quadrilateral cubes arranged as a line in series in the pixel region, the line is parallel to the first direction, and at least one portion of each of the quadrilateral cubes in the same series is overlapped by an adjacent quadrilateral cube.
- 8. The LCD of claim 7, wherein two sides of the quadrilateral cubes are parallel to one of the first polarization direction and the second polarization direction respectively, and the other two sides of the quadrilateral cubes are parallel to the other one of the first polarization direction and the second polarization.
- 9. The LCD of claim 7, wherein the quadrilateral cubes are rhombus cubes.
- 10. The LCD of claim 7, wherein any two adjacent sides of each of the quadrilateral cubes have an included angle of 90 degrees.
- 11. The LCD of claim 1, wherein the liquid crystal molecules deform to have optical anisotropicity when an electrical field is applied to the pixel region.
- 12. The LCD of claim 11, wherein the liquid crystal molecules are blue phase liquid crystal (BPLC) molecules.
- 13. The LCD of claim 11, when the electrical field is applied to the pixel region, the pixel region displays a bright state.
- 14. The LCD of claim 11, wherein the electrical field is a lateral electrical field.
- 15. The LCD of claim 1, the liquid crystal molecules near the majority portion of the edge of the pixel electrode deform to have optical anisotropicity along with the edge of the pixel electrode.
- 16. The LCD of claim 1, wherein the first direction is not parallel to the first and second polarization directions.
- 17. The LCD of claim 16, wherein the first direction and the first or the second polarization directions have an included angle of 45 degrees.
- 18. The LCD of claim 1, wherein the pixel region further comprises a passivation layer disposed between the pixel electrode and the lower substrate, the passivation layer has at least one slit corresponding to the edge of the pixel electrode, and the passivation layer with the slit and the pixel electrode compose a groove structure.

* * * * *